

BIONICS BASED APPROACH FOR TREATMENT OF EPILEPSY

Shweta Gupta¹, Shashi Kumar Singh²

^{1,2} *Electronics and Communication Department, Dr. K.N. Modi University, Newai, Rajasthan, (India)*

ABSTRACT

Bionics plays an important role in the treatment of Epilepsy using memristors. Bionics is the branch of science in which we study nature and find solutions to human problems. Echo state networks (ESN) or reservoirs, are random, recurrent neural network topologies that integrate temporal data over short time windows by operating on the edge of chaos. Recently, there is a significant effort on the mathematical modeling and software topologies of the reservoirs. However, hardware reservoir fabrics are essential to deploy in energy constrained environments. In this paper, we investigate a hardware reservoir with bi-stable memristive synapses. In particular, we demonstrate a scalable hardware model for detecting real-time epileptic seizures in human models. The performance of the proposed reservoir hardware is evaluated for absent seizure signals with 85% accuracy.

Keywords: *Bionics, Echo State Networks, Epilepsy Seizure, Memristors, Reservoir Computing, Seizure detection*

I. INTRODUCTION

Spatiotemporal signal processing problems arise in a diverse set of application domains, including image and video analysis, anomaly detection, and load forecasting. For several of these applications, it is difficult to identify *a priori* which features of the spatiotemporal signal are critical for use in the classification/prediction model. A model that encapsulates the continuous perturbations has been demonstrated by the reservoir computing [1]. In the echo state networks (ESN), the reservoir (a recurrent neural network) is generated randomly, and only the read-out from the reservoir is trained. The ESN model enables computation with non-conventional hardware. Feedback connections within the ESN enable it to extract both spatial and temporal components of features within time series data. Software ESN models have shown promise in several applications, including emotion recognition [2], natural language analysis, motion identification, speech recognition [3], and many more (see for a review). However, hardware implementations are necessary for applications where performance and energy efficiency are the primary design criteria (*e.g.* in energy constrained environments such as therapeutic devices and body sensors). In this work, we focus on detecting epileptic seizures which is a chronic disorder of the central nervous system affecting 50 million people across the world [4].

Seizure, an aberration in the brain activity, can be often detected through analysis of

electroencephalogram (EEG) signals. The EEG is an appropriate area for nonlinear time series analysis techniques such as ESN, with deterministic chaos. A software ESN model has been used for epileptic seizure detection. In this work a hardware implementation ESN based on memristive devices is used.

Specific contributions of this research study are,

- ESN Hardware architecture which is simple, scalable, and computationally inexpensive using nanoscale memristive elements.
- Random reservoir topology for the epileptic seizure detection.
- Memristive synapse circuit primitives using bi-stable devices.

The rest of the paper is organized as follows. Section 2 provides an overview of the hardware architecture and the proposed synapse circuit design with bi-stable memristors. Section 3 discusses the epilepsy seizure detection application and Section 4 presents the seizure detection results with the proposed hardware model. Section 5 concludes this work.

II. PROPOSED HARDWARE ARCHITECTURE

The core of the proposed reservoir architecture model, shown in Figure 1, consists of a reconfigurable cellular automata [5] based ESN, whose global evolution is determined by a transition rule. Based on the transition rules at each neuron (cell) status updates are passed onto neighboring neurons (cells). The analog output state of each of the neurons is dissipated to the output layer. Each neuron has two inbound and two outbound signals between the neighboring cells. Reconfigurable connectors pass these signals from each neuron using crossbar routing channels. These crossbar routing channels can exploit memristor crossbar structures. However, in this exploratory work all the routing channels are CMOS based.

The routing complexity and associated hardware cost increases significantly, when implementing ESN reservoirs with a high degree of connectivity. For a pragmatic hardware architecture, we explored two sparsely-connected reservoir topologies - i) ring and ii) random. In both topologies, the reservoir is fully connected to input and output layers. The ring topology was designed based on the ESN proposed in [6]. In the ring topology (Figure 2) reservoir neurons are connected only to adjacent neurons. Each neuron has two output connections and two input connections. The same number of connections are used in the random topology (Figure [6]). These connections are randomly initialized with two restrictions: i.) There are no connections from a neuron back to itself and ii.) the two output connections of a neuron cannot be connected to another single neuron.

Weights between the inputs and the reservoir neurons are never trained after being randomly initialized. It is therefore unnecessary to have bipolar synapses (weights that can be positive or negative) between these groups of neurons, and instead only unipolar positive or negative synapses are needed. The weights between the reservoir neurons and output neurons require training, but bipolar synapses are still unnecessary. Instead the weights are initialized randomly, but during training they are configured to not alter the polarity. This simplifies the synapse design and also reduces the overall area of the ESN.

III. BI-STABLE MEMRISTOR-BASED SYNAPSE DESIGN

Two synapse circuits are designed with bi-stable memristors, an excitatory synapse and an inhibitory synapse, as shown in Figure 3.

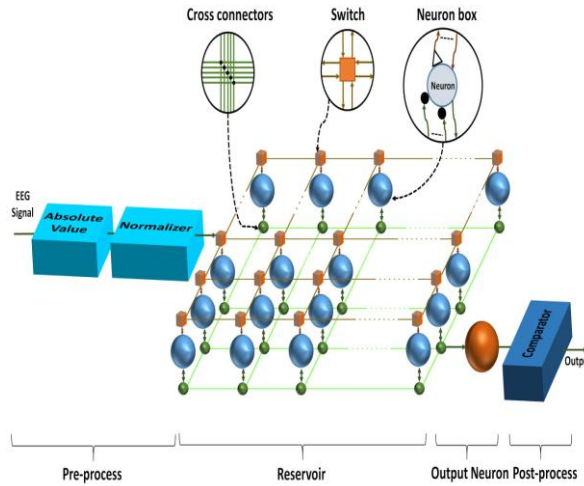

Figure 1: High-level depiction of the ESN architecture. The core reservoir is based on the cellular automata architecture with reconfigurable crossconnectors, enabling dynamic configuration of different ESN topologies. The output node is implemented using bi-stable memristive synapses.

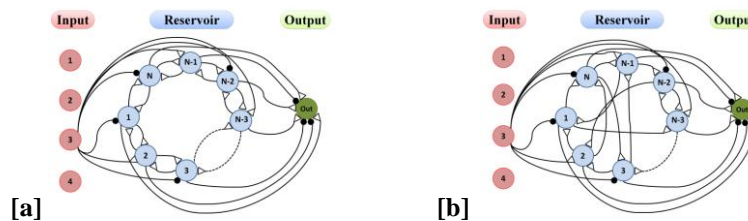

Figure 2: Block level representations of the two ESN topologies that can be embedded in the proposed architecture.[a] Ring topology and [b] Random topology. All the simulations for the hardware architecture are performed with random topology.

Each of these circuits constitute two bi-stable memristors in parallel. The inhibitory synapse draws current away from a post-synaptic neuron, lowering the potential at its input, similar to the behavior of a GABAergic synapse in a biological brain. The excitatory synapse supplies current to the post-synaptic neuron, raising its input potential, which is similar to a glutamatergic synapse in a biological brain.

The weights of the inhibitory (w^-) and excitatory (w^+) synapses are determined by the ratio of their memristor conductances

$$w_{\sim}(+) = G \frac{G_{2(4)}}{1(3) + G_{2(4)}} \quad (1)$$

where $G = 1/R$, is the conductance of memristor in Figure 3.

The combination of the R_{on} and R_{off} of the memristors represents different weight values. Each memristor is connected to a diode-connected transistor, and the output of the synapse circuit is delivered through a current mirror (transistor $M3$ for the inhibitory synapse in Fig.3(a) and transistor $M6$ for the excitatory synapse in Fig.3(b)).

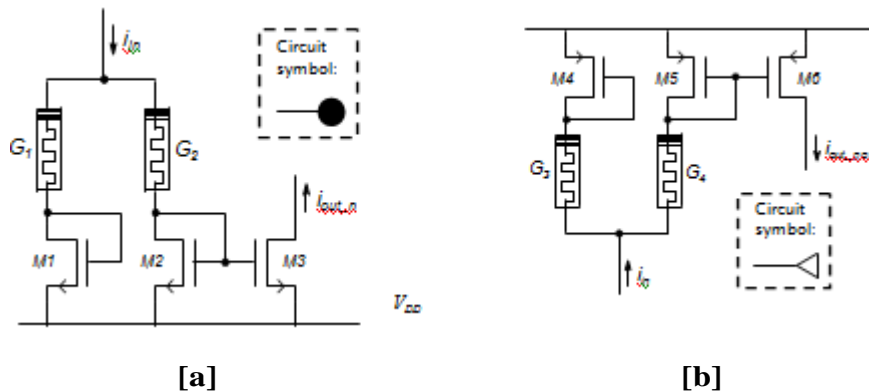

Figure 3: [a] Inhibitory memristive synapse circuit and [b] excitatory memristive synapse circuit. These circuits are inspired by the function of biological inhibitory (e.g. GABAergic) and excitatory (e.g. glutamatergic) synapses with ionotropic receptors

All transistors within a synapse circuit have the same size, where the ratio of $(W/L)_{PMOS} : (W/L)_{NMOS} = 4:1$.

IV. NEURON DESIGN

A current-mode neuron circuit with sigmoid ('S'-shaped) activation function was designed using a MOSFET differential pair and a current mirror (Figure 4). From a biological perspective the neuron's output represents the neuron firing rate. The neuron output current, i_{out} , is based

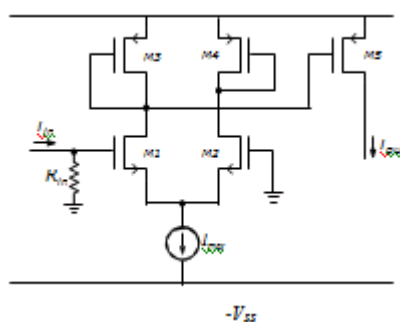

Figure 4: Proposed neuron circuit for the reservoir and output layers of the ESN. The input- output relationship, or activation function, has a sigmoid ('S') shape.

on the gate voltage difference between the MOSFET differential pair (transistor $M1$ and $M2$). Since the gate terminal of $M2$ is always biased to ground, i_{out} only depends on input current, i_{in} , and input resistance, R_{in} .

The sizing of each transistor in the neuron circuit is similar to those of the synapse circuit, where $(W/L)_{PMOS} = 25$ and $(W/L)_{NMOS} = 16$, to ensure that the same current is being transferred between neuron and synapse circuits [7].

V. APPLICATION TO EPILPESY SEIZURE DETECTION

Epilepsy is the fourth most common neurological disorder, where one in 26 people will develop this disorder at sometime in their life. There are a few therapeutic interventions possible for treating seizures. However, detecting the onset of a seizure, by automatic monitoring of EEG data, will aid the doctors/emergency responders to provide appropriate drug dosage based on the remaining epileptic activity. The common pattern in the case of seizures is that the brains electrical signals repeat themselves [8].

Using an RC based hardware device to detect these seizures can serve three purposes.

1) Serves as an early alert system to preclude any unwanted exertion; 2) Controlled delivery of drugs to reduce the side effects; and 3) Continual monitoring for proactive interventions for antiepileptic drug failures. The RC hardware device can operate in two modes 1) seizure onset detector and 2) seizure event detector [9]. The onset detector will capture the seizures at extremely low latency but not high accuracy. The event detector will capture the seizures with utmost precision but not necessarily with low latency. In this research our hardware architecture focuses on the onset detection [10].

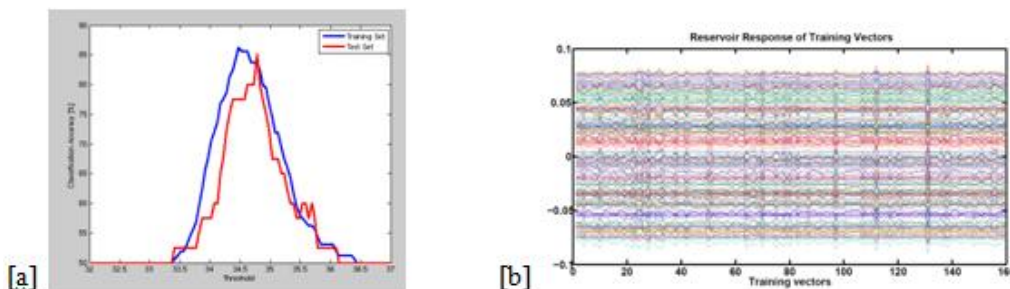

Figure 5: [a] The accuracy of detecting the epileptic seizure using the limited-precision ESN hardware architecture. The maximum test accuracy is 85%. [b] ESN reservoir response to all of the training vectors.

The dataset we have used in this research was presented in Fig.[5]. It consists of 500 single-channel EEG segments of 23.6 sec recorded at sampling rate of 173.61 Hz. The dataset was divided into five sets (denoted A-E), each set contains 100 EEG segments [11]. The set A, which contains surface EEG recordings of five healthy volunteers, and E which contains seizure activity segments taken from five patients, were used in this research. The dataset is publicly available at [12].

We trained and tested the proposed ESN design using a total of 200 EEG signals (160 for training and 40 for testing). The ESN reservoir contained 200 sigmoid neurons with 90% random connectivity. A single input—the absolute normalized EEG signal—was connected to each of the reservoir neurons through a random weight vector. Each of the reservoir outputs was fed into a linear readout layer which was trained to detect seizure activity. We used a hardware-in-the-loop training methodology where the dynamic outputs of the ESN reservoir are collected off-chip for each of the training vectors. These responses are used to calculate the output layer weights using a linear regression in MATLAB. The final output weights are transferred back to the hardware.

Figure 4 shows training and test accuracies for different threshold values. The test set is able to reach $\approx 85\%$ accuracy. Figure 4 shows the reservoir's response to each of the training vectors. It may be possible to improve the test accuracy by optimizing (*e.g.* via genetic algorithm) the ESN parameters such as connectivity, spectral radius of the weight matrix, reservoir activation function, etc.

VII. CONCLUSION AND FUTURE WORK

We proposed an inherently parallel cellular automata architecture to realize reservoirs, for solving complex spatio-temporal problems in real-time. The proposed design considers memristive hardware primitives (synapses), where multiple weight states are achieved using multiple bi-stable memristors. Experimental data shows that bi-stable memristors are physically plausible to manufacture than those with continuously-varying conductances. The epileptic seizure signal detection was within 0.06 seconds time window and the accuracy is 85%. Though the exemplary seizure detection case demonstrated in this work has slightly lower accuracy, the results show lot of promise considering that we have used limited precision devices. Future work will focus on increasing the classification accuracy by fine tuning the parametric models and increasing the number of weight states per synapse.

REFERENCES

- [1] <http://www.epilepsy.com/>.
- [2] Ralph G Andrzejak, Klaus Lehnertz, Florian Mormann, Christoph Rieke, Peter David, and Christian E Elger. Indications of nonlinear deterministic and finite-dimensional structures in time series of brain electrical activity: Dependence on recording region and brain state. *Physical Review E*, 64(6):061907, 2001.
- [3] Ralph G. Andrzejak, Klaus Lehnertz, Florian Mormann, Christoph Rieke, Peter David, and Christian E. Elger. Indications of nonlinear deterministic and finite-dimensional structures in time series of brain electrical activity: Dependence on recording region and brain state. *Phys. Rev. E*, 64:061907, Nov 2001.
- [4] Pieter Buteneers, Benjamin Schrauwen, David Verstraeten, and Dirk Stroobandt. Epileptic

- seizure detection using reservoir computing. In *19th Annual Workshop on Circuits, Systems and Signal Processing*, 2008.
- [5] K Ishu, Tijn van Der Zant, Vlatko Becanovic, and P Ploger. Identification of motion with echo state network. In *OCEANS'04. MTTs/IEEE TECHNO-OCEAN'04*, volume 3, pages 1205–1210. IEEE, 2004.
- [6] Herbert Jaeger. The echo state approach to analysing and training recurrent neural networks– with an erratum note. *Bonn, Germany: German National Research Center for Information Technology GMD Technical Report*, 148:34, 2001.
- [7] Matilde Leonardi and T Bedirhan Ustun. The global burden of epilepsy. *Epilepsia*, 43(s6):21–25, 2002.
- [8] Mantas Lukoševičius, Herbert Jaeger, and Benjamin Schrauwen. Reservoir computing trends. *KI-Künstliche Intelligenz*, 26(4):365–371, 2012.
- [9] Ali Rodan and Peter Tino. Minimum complexity echo state network. *Neural Networks, IEEE Transactions on*, 22(1):131–144, 2011.
- [10] Stefan Scherer, Mohamed Oubbati, Friedhelm Schwenker, and Günther Palm. Real-time motion recognition from speech using echo state networks. In *Artificial neural networks in pattern recognition*, pages 205–216. Springer, 2008.
- [11] Mark D Skowronski and John G Harris. Automatic speech recognition using a predictive echo state network classifier. *Neural networks*, 20(3):414–423, 2007.
- [12] Matthew H Tong, Adam D Bickett, Eric M Christiansen, and Garrison W Cottrell. Learning grammatical structure with echo state networks. *Neural Networks*, 20(3):424–432, 2007.