

FAULT ANALYSIS IN MULTI-LEVEL CONVERTER STATCOM WITH DIFFERENT MODULATION TECHNIQUES

D.Suresh¹, A.Mohandas², U Madhuri³

*¹PG Scholar, ²Associate Professor, Dept of EEE, Teegala Krishna Reddy Engineering College,
Meerpet, Hyderabad, (India)*

³PG Scholar, Dept of EEE, SRIDEVI Women's Engineering College, Hyderabad, (India)

ABSTRACT

Static synchronous compensators (STATCOMs) utilize multilevel converters due to the following: 1) lower harmonic injection into the power system; 2) decreased stress on the electronic components due to decreased voltages; and 3) lower switching losses. One disadvantage, however, is the increased likelihood of a switch failure due to the increased number of switches in a multilevel converter. A single switch failure, however, does not necessarily force an $(2n + 1)$ -level STATCOM offline. Even with a reduced number of switches, a STATCOM can still provide a significant range of control by removing the module of the faulted switch and continuing with $(2n - 1)$ levels. This paper introduces an approach to detect the existence of the faulted switch, identify which switch is faulty, and reconfigure the STATCOM. This approach is illustrated on 13-level STATCOM and the effect on the dynamic performance and the total harmonic distortion (THD) is analyzed with different pulse width modulation (PWM) techniques.

Keywords: *Fault Detection, Multi Level Converter, Static Synchronous Compensator (STATCOM), PWM Techniques.*

I. INTRODUCTION

Injection of the wind power into an electric grid affects the power quality. The performance of the wind turbine and thereby power quality are determined on the basis of measurements and the norms followed according to the guideline specified in International Electro-technical Commission standard, IEC-61400. The influence of the wind turbine in the grid system concerning the power quality measurements are-the active power, reactive power, variation of voltage, flicker, harmonics, and electrical behaviour of switching operation and these are measured according to national/international guidelines.

The paper study demonstrates the power quality problem due to installation of wind turbine with the grid. In this proposed scheme Static Compensator (STATCOM) is connected at a point of common coupling with a battery energy storage system (BESS) to mitigate the power quality issues. The battery energy storage is integrated to sustain the real power source under fluctuating wind power. The STATCOM control scheme for the grid

connected wind energy generation system for power quality improvement is simulated using MATLAB/SIMULINK in power system block set. The effectiveness of the proposed scheme relieves the main supply source from the reactive power demand of the load and the induction generator. The development of the grid co-ordination rule and the scheme for improvement in power quality norms as per IEC-standard on the grid has been presented. An approach of detecting the existence of the fault switch identifies the switch which is faulty and reconfigures the STATCOM. This approach is illustrated on an eleven-level STATCOM and the effect on the dynamic performance and the total harmonic distortion [1]. The PWM techniques include Phase Disposition (PD) PWM, Phase Opposition and Disposition (POD) PWM, Alternative Opposition and Disposition (APOD) PWM, Carrier Overlapping (CO) PWM, Phase Shift (PS) PWM and Variable Frequency (VF) PWM and the harmonics of the output voltages are observed for various modulation indices [2]. A new control method of cascaded connected H-bridge converter-based static compensators. These converters have classically been commutated at fundamental line frequencies, but the evolution of power semiconductors has allowed the increase of switching frequencies and power ratings of these devices, permitting the use of pulse width modulation techniques [3]. A study of consequences of faults in hard-switching and soft-switching multi cell converters. Solutions to minimize the consequences of major faults are described [4]. A fault-tolerant operation strategy of three-level neutral-point-clamped PWM inverters in high power, high performance, safety-critical applications. Likely faults are identified and fault-tolerant schemes based on the inherent redundancy of voltage vectors of neutral-point-clamped inverters are presented [5].

A reconfiguration system based on bi-directional electronic valves has been designed for a 3-phase cascaded H-bridge. Once a fault is detected in any of the IGBTs of any H-bridge, the control is capable to reconfigure the hardware at the faulty phase by means of eliminating the damaged bridge. If the faulty bridge is not the smallest one, then the bi-directional-valve system reconfigure the faulty phase to keep the higher power bridges in operation. In this way, that phase can continue working at the same voltage level by adjusting its gating signals [6].

A new type of multilevel inverter is introduced which is created by cascading two three-phase three-level inverters using the load connection, but requires only one dc voltage source. This new inverter can operate as a seven-level inverter and naturally splits the power conversion into a higher-voltage lower-frequency inverter and a lower-voltage higher-frequency inverter [7]. A method is based on high frequency harmonic analysis, using a dynamic prediction of their behavior, avoiding false detection on transients while keeps the precision under fault events.

Once the faulty cell is detected, it can be short circuited allowing the converter to keep working according to previously reported techniques [8]. The modeling of harmonic sources with nonlinear voltage-current characteristics such as transformers, iron-core reactors, rotating machines, arc furnaces, energy efficient lightings, and some household electronic appliances. The harmonic generating characteristics of these apparatus are reviewed. Different modeling techniques are summarized and suggestions for the use of different models are also provided whenever possible [9].

A new nonlinear control for the STATCOM that provides significant reduction in EAF-induced a periodic oscillations on the power system. This method is compared with traditional PI controls and has shown to have improved performance [10]. An approach to detect the existence of the faulted switch, identify which switch is faulty, and reconfigure the STATCOM. This approach is illustrated on 13-level STATCOM and the effect on

the dynamic performance and the total harmonic distortion (THD) is analyzed with different pulse width modulation (PWM) techniques in this proposed paper.

II. FAULT ANALYSIS IN MULTI-LEVEL CONVERTER STATCOM

The proposed STATCOM control scheme for grid connected wind energy generation for power quality improvement has following objectives.

- Fault detection and removal of faults in STATCOM within the minimum time period.
- Percentage (%) THD comparison for different PWM Technique .
- Simple bang-bang controller for STATCOM to achieve fast dynamic response.

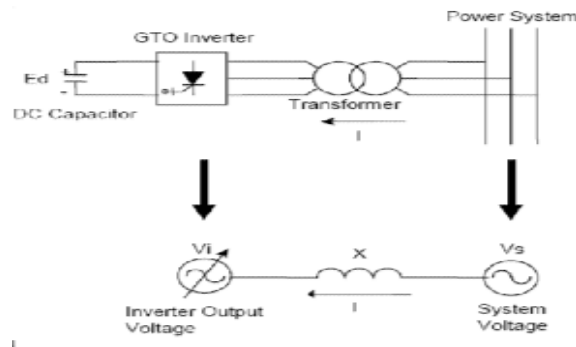

Fig.1: STATCOM Connected with Power Grid

III. SYSTEM CONFIGURATIONS

The single line diagram of the electrical distribution system feeding an RL load is shown in Fig.2. The STATCOM has been shown to be an efficient controller to mitigate arc furnace flicker. The electrical network consists of a 11KV generator and an impedance that is equivalent to that of a large network at the point of common coupling (PCC).

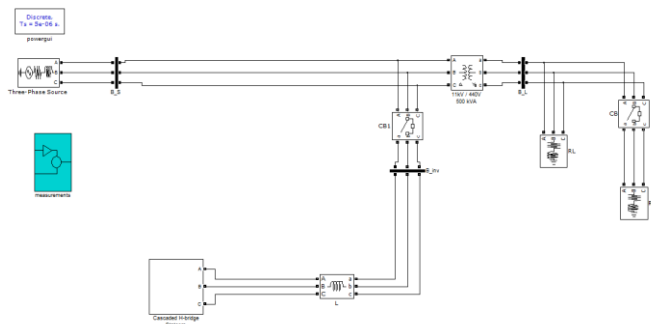

Fig.2: STATCOM Connected to the Power.

Cascaded multilevel STATCOM contains 6 H-bridges in series to synthesize a staircase waveform. The inverter legs are identical and are therefore modular.

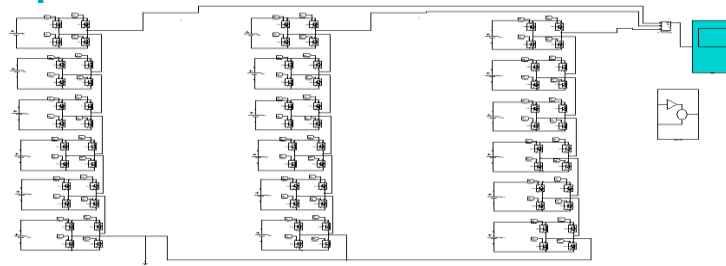

Fig.3: 13-Level Cascaded STATCOM Circuit Design in Simulink

In the 13-level STATCOM, each leg has 6 H-bridges as shown in fig:3. Since each full bridge generates three different level voltages ($V, 0, -V$) under different switching states, the number of output voltage levels will be thirteen.

IV. POWER GRID WITHOUT STATCOM

The single line diagram of the electrical distribution system feeding an RL load without STATCOM is shown in Fig.4.

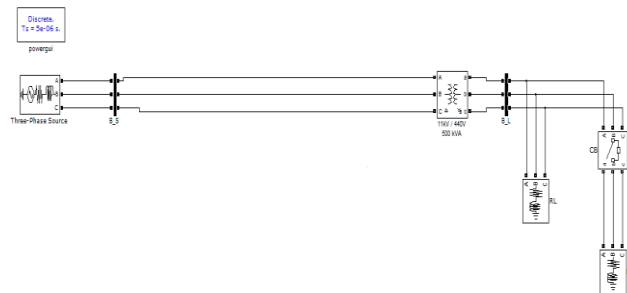

Figure.4. Power Grid without STATCOM

By the removing the STATCOM from grid circuit the output voltage is 1p.u. value before connection of the load and it reduces to 0.6p.u.as shown in figure 5.

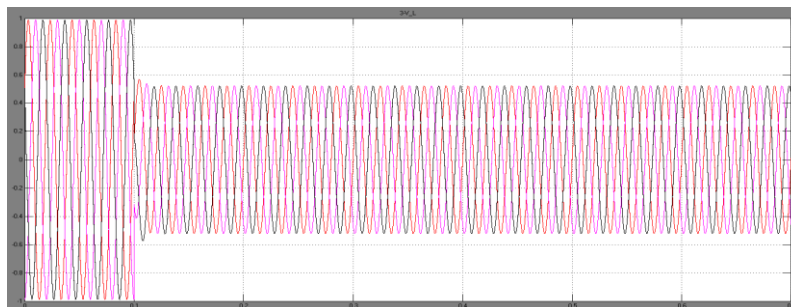

Figure.5. Output Voltage without STATCOM

The %THD values for load current and load voltage are 48.25% and 32.23% are respectively and the following output wave forms are shown in figure.6 without the STATCOM.

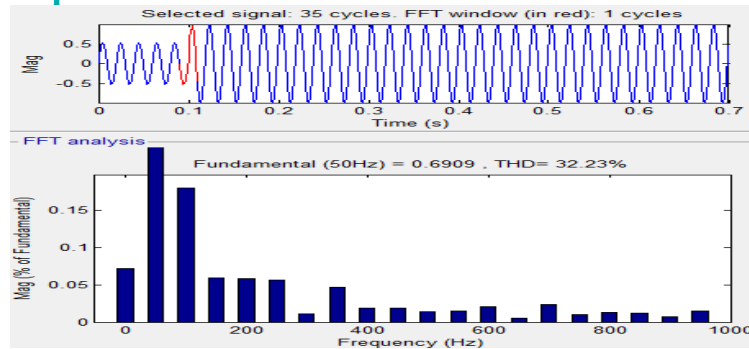

Figure.6. %THD Value for Load Voltage without STATCOM

V. IMPLEMENTATION OF LEVEL SHIFTED PULSE WIDTH MODULATION IN 13 LEVEL STATCOM CONNECTED TO A GRID

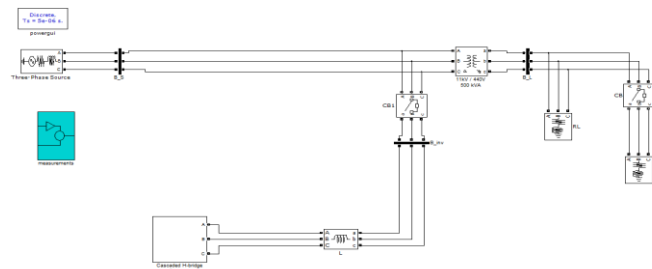

Fig.7. STATCOM Connected to the Power

The STATCOM is connected to the system through a Y-Delta transformer at $t=0.2$ seconds then the output voltage will reach the normal position (1 per unit).

5.1 Level Shifted Pulse Width Modulation

Modulation methods developed for multilevel inverters involve multilevel sinusoidal pulse width modulation, multilevel selective harmonic elimination and space-vector modulation. It is generally accepted that the performance of any inverter, with any switching strategy can be related to the harmonic contents of its output voltage. There are many control techniques reported for cascaded multilevel inverter. But the popularly used modulation method is the multicarrier level shifted PWM technique. Level shifted PWM technique is the generally used method in cascaded multilevel inverter as it gives a reduced THD. In this paper, fixed frequency PWM is proposed which uses the conventional sinusoidal reference signal and the carrier signals with variable frequency.

In this paper, fixed frequency PWM is proposed which uses the conventional sinusoidal reference signal and the carrier signals with variable frequency. To implement a m -level inverter, $(m-1)$ carriers are used. There are 12 carriers with fixed frequency and with the same magnitudes for the seven level multilevel inverter, the difference between the carriers is that they are all displaced by a set of DC offset. The frequency modulation index is given by $m_f = f_c / f_m$.

Where, f_c = carrier frequency f_m = modulating waveform frequency.

The amplitude modulation indices are for (i) PDPWM, PODPWM, APODPWM

$$2Ar/(m-1) *Ac.$$

(i): Phase Disposition Modulation Method (PDPWM):

The figure 8. Shows the simulink circuit design for PDPWM technique pulse generation. In phase disposition method all the carriers have the same frequency and amplitude. Moreover all the N-1 carriers are in phase with each other. It is based on a comparison of a sinusoidal reference waveform with vertically shifted carrier signals. This method uses N – 1 carrier signals to generate N level inverter output voltage. All the carrier signals have the same amplitude, same frequency and are in phase. In this method 12-triangular carrier waves are modulated with the one sinusoidal reference wave as shown in figure.8.

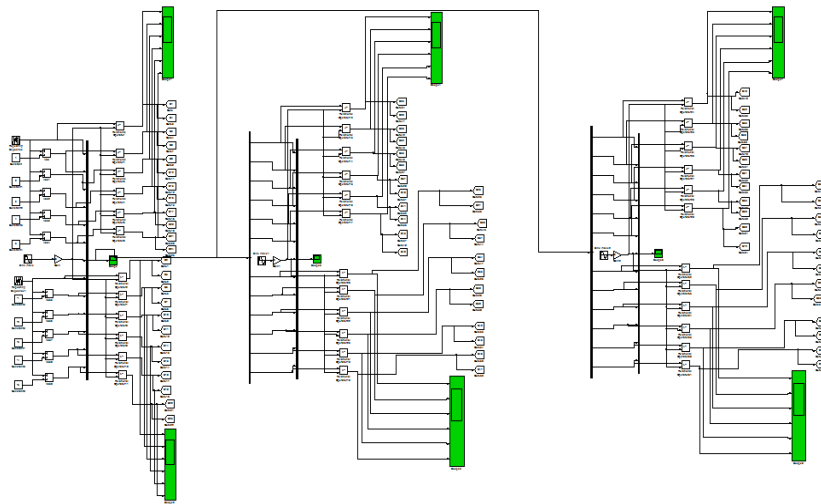

Figure.8: 13-Level Converter Sub-Circuit for Pulse Generation for PDPWM Technique

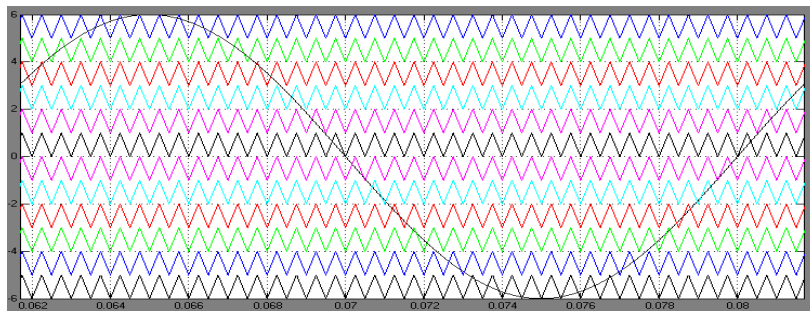

Figure.9: Carrier signals arrangement for PDPWM strategy

(ii) Phase Opposition Disposition PWM (PODPWM):

The figure.10 Shows the Simulink Circuit Design for PODPWM Technique Pulse Generation.

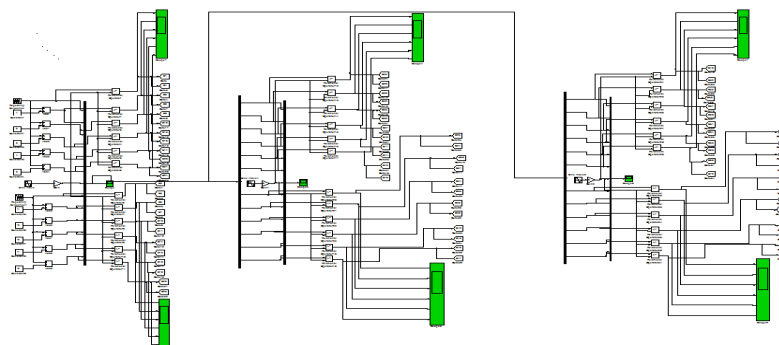

Figure.10: 13-Level Converter Sub-Circuit for Pulse Generation for PODPWM Technique.

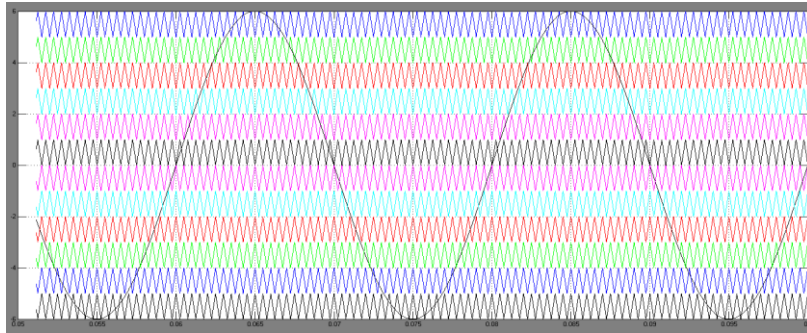

Figure.11: Carrier Signals Arrangement for PODPWM Strategy

In Phase Opposition Disposition (POD), the carrier signal above the zero axis all the carrier wave have same frequency, same amplitude and in phase each other. But the below the zero axis all the carrier wave have same frequency, same amplitude and in phase but all carrier wave have phase shifted 180 degree compare to the above zero axis carrier waveform. In this method 12-triangular carrier waves are modulated with the one sinusoidal reference wave as shown in figure.11.

(iii) Alternate Phase Opposition Disposition PWM (APODPWM):

In Alternate Phase Opposition Disposition PWM (APOD), every carrier waveform is out phase with its neighbouring carrier wave by 180 degree. All the carrier waveform have same frequency, same amplitude and but compare one carrier waveform to neighbour carrier waveform is phase shifted 180 degree. Odd carrier waveforms are in phase but compare to even carrier waveform are out of phase shift 180 degree in odd carrier waveform.

VI. FAULTS IN CONVERTER

The Open circuit or Short circuit Fault is created in the 13-level converter STATCOM in 3rd cascaded H-bridge in the phase-A. The fault is entered in circuit by the a unit step function at a time interval t=0.5 seconds in switch No.3 in phase-A as shown in figures.12 (a & b) schematic circuits for open circuit and short circuit respective faults.

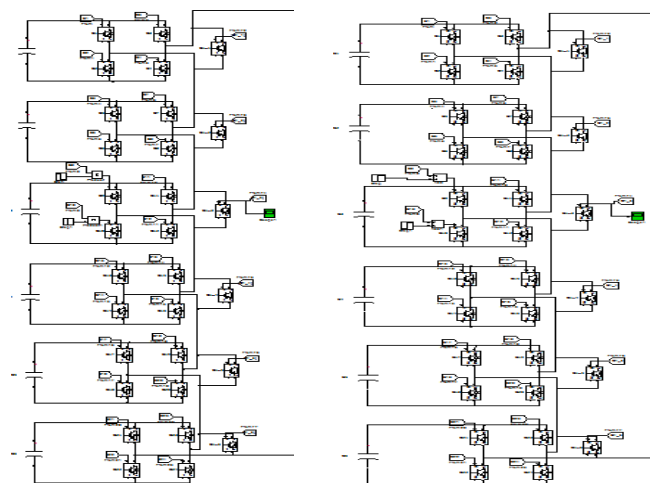

Figure 12.a) Open circuit fault in 3rd H-bridge Converter, b) Short circuit fault in 3rd H-bridge Converter

At this time the capacitor voltages is suddenly increases in 3rd H-bridge converter for open circuit fault and capacitor voltage decreases in 3rd H-bridge converter for short circuit faults as shown in figures.13(a & b).

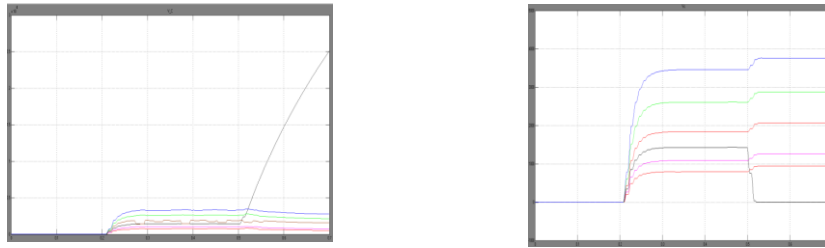

Figure.13 (a&b): Capacitor Voltages at a) OC Fault b) SC Fault

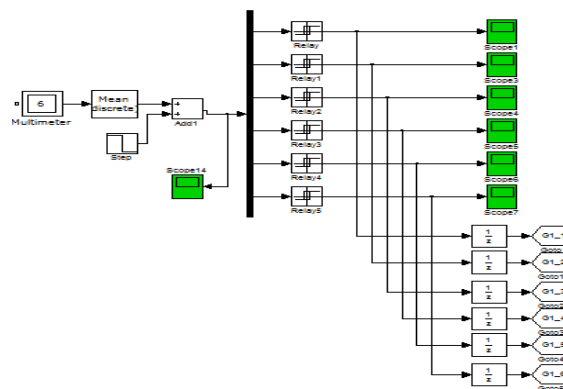

Figure.14: Control Circuit for Identifying and Removing the OC and SC Fault.

The control a circuit is helps to generate the pulses at the time interval of any fault by the help of relay circuit. The signal is generated at 0.52 seconds as shown in figure 14. And the gating signal of cell 3 by-pass switch. The RL load is launched at 0.1second,the STATCOM is connected at 0.2 seconds, So the voltage of the grid is busted by STATCOM with reduced voltage value and operates in steady state condition.

A Open circuit or a short circuit fault is introduced in the 3rd cascaded H-bridge in the phase-A of the STATCOM at the time=0.5 seconds. Due to this fault a voltage drop is created in phase-A voltage. Then the relay is activated and clears the fault with in 0.023 seconds.

STATCOM Output voltages and %THD values for different PWM techniques:

By connecting a 13-level Converter STATCOM to the 11KV Power grid line the following output voltage wave forms are produced as shown in below figures:

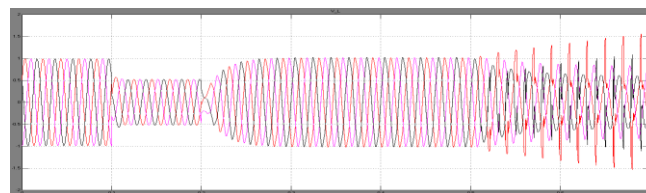

(a): RMS output voltage of STATCOM without by-pass circuit for OC fault in PDPWM technique.

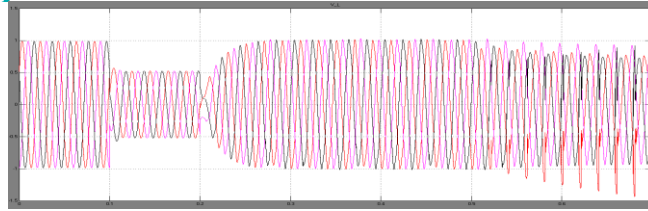

(b): RMS output voltage of STATCOM before, during and after the fault for OC fault in PDPWM technique.

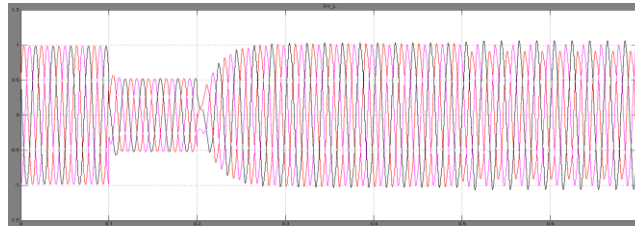

(c): RMS output voltage of STATCOM without by-pass circuit for SC fault in PDPWM technique

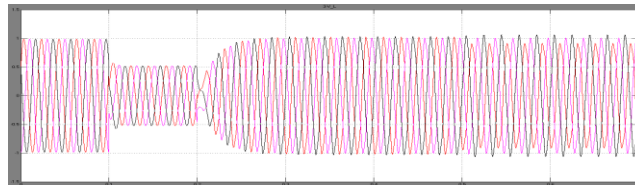

(d): RMS output voltage of STATCOM before, during and after the fault for SC fault in PDPWM technique.

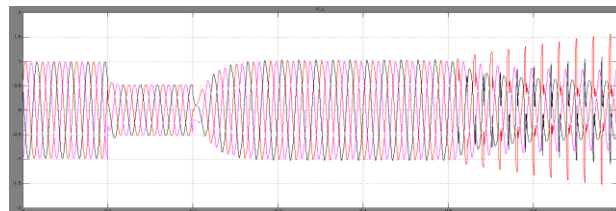

(e): RMS output voltage of STATCOM without by-pass circuit for OC fault in PODPWM technique

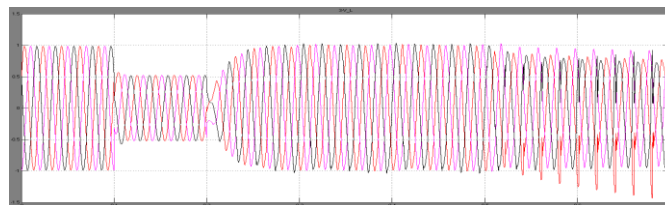

(f): RMS output voltage of STATCOM before, during and after the fault for OC fault in PODPWM technique.

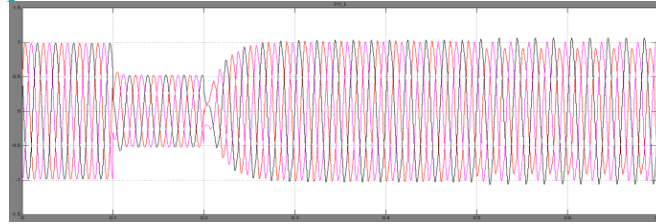

(g): RMS output voltage of STATCOM without by-pass circuit for SC fault in PODPWM technique

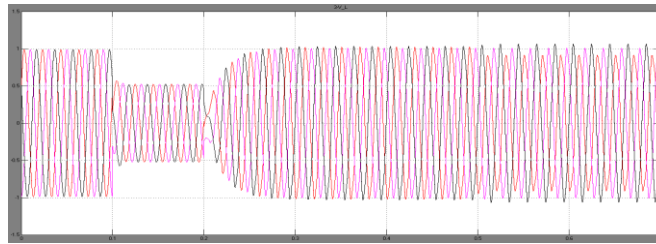

(h): RMS output voltage of STATCOM before, during and after the fault for SC fault in PODPWM technique.

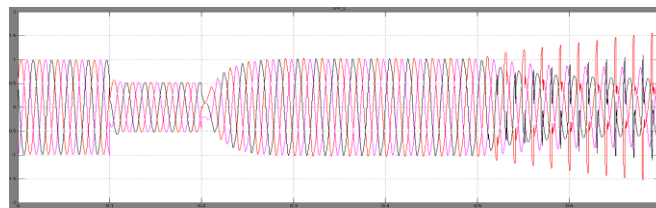

(i): RMS output voltage of STATCOM without by-pass circuit OC fault in APODPWM technique.

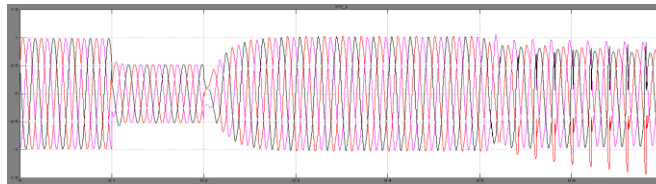

(j): RMS output voltage of STATCOM before, during and after the fault for OC fault in APODPWM technique.

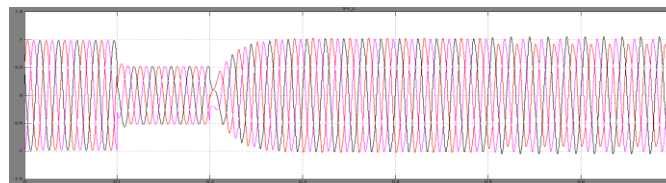

(k): RMS output voltage of STATCOM without by-pass circuit for SC fault in APODPWM technique

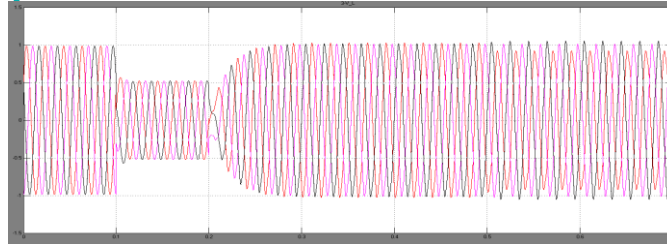

(l): RMS output voltage of STATCOM before, during and after the fault for SC fault in APODPWM technique.

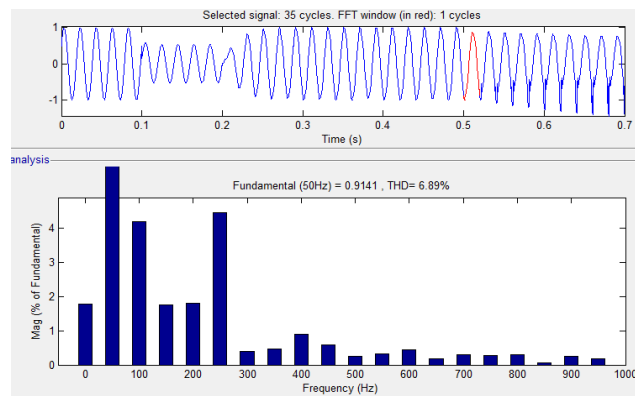

(m): %THD for load voltages before, during and after the fault for OC fault in PDPWM technique

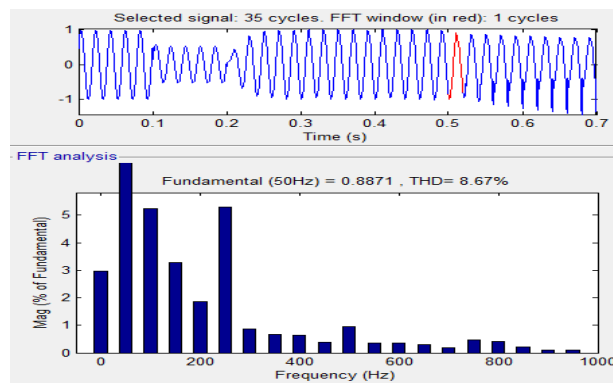

(n): %THD for load voltages before, during and after the fault for OC fault in PODPWM technique

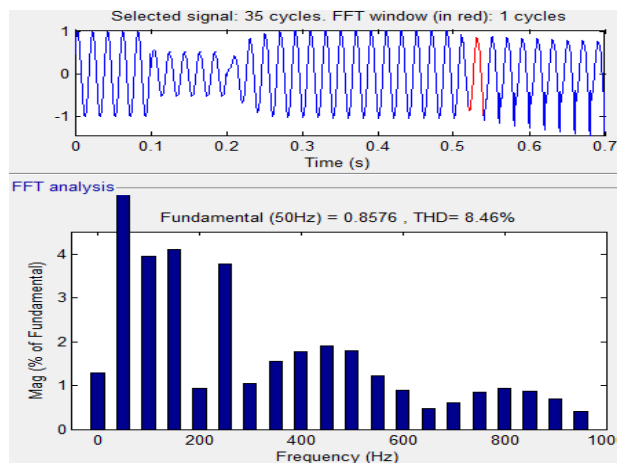

(o): %THD for load voltages before, during and after the fault for OC fault in APODPWM technique.

The following tables 1. shows that comparisons of %THD values of load voltages and load current for different PWM techniques.

Table.1:

S.N O	PWM TECH NIQU ES	LOAD VOLTAGE WITHOUT BY- PASS CIRUIT		LOAD VOLTAGE WITH BY-PASS CIRUIT	
		OC	SC	OC	SC
		FAULT	FAULT	FAULT	FAULT
1	PD	18.82%	88.06 %	6.89%	6.69%
2	POD	19.05%	5.65%	8.67%	5.61%
3	APOD	12.04%	5.65%	8.46%	5.30%

- Fault replaced time is 0.023 seconds in this experiment but in the proposed paper the fault operating time is 300ms.
- %THD values without STATCOM for load current and load voltage are 48.25% and 32.23% are respectively.
- But with STATCOM %THD for OC fault PDPWM, PODPWM and APODPWM techniques are 6.89%, 8.67% and 8.46% respectively. For SC fault these values are 6.69%, 5.61% and 5.30 % .Therefore APODPWM Technique having the less values of %THD comparing with other techniques.

Vii. CONCLUSION

In this paper, a fault detection and mitigation strategy for a 13-level cascaded converter has been proposed. This approach requires no extra sensors and only one additional bypass switch per module per phase. The approach has been validated on a 11-kV system with a STATCOM compensating an electric arc furnace load. This application was chosen since the arc furnace provides a severe application with its non-sinusoidal, unbalanced, and randomly fluctuating load. The proposed approach was able to accurately identify and remove the faulted module. In addition, the STATCOM was able to remain in service and continue to provide compensation without exceeding the total harmonic distortion allowances.

REFERENCES

[1]. Atousa Yazdani, Member, IEEE, Hossein Sepahvand, Student Member, IEEE, Mariesa L. Crow, Fellow, IEEE, and Mehdi Ferdowsi, Member, IEEE “Fault Detection and Mitigation in Multilevel Converter STATCOMs”, IEEE TRANSACTIONS ON INDUSTRIAL ELECTRONICS, VOL. 58, NO. 4, APRIL 2011.

- [2]. E.Sambath, S.P. Natarajan, C.R.Balamurugan, "Performance Evaluation of Multi Carrier Based PWM Techniques for Single Phase Five Level H-Bridge Type FCMLI", IOSR Journal of Engineering (IOSRJEN) ISSN: 2250-3021 Volume 2, Issue 7(July 2012), PP 82-90.
- [3]. Jon Andoni Barrena, Luis Marroyo, "Individual Voltage Balancing Strategy for PWM Cascaded H-Bridge Converter-Based STATCOM", IEEE TRANSACTIONS ON INDUSTRIAL ELECTRONICS, VOL. 55, NO. 1, JANUARY 2008.
- [4]. Christophe Turpin, Philippe Baudesson, Frédéric Richardeau, François Forest, and Thierry A. Meynard "Fault Management of Multicell Converters", IEEE TRANSACTIONS ON INDUSTRIAL ELECTRONICS, VOL. 49, NO. 5, OCTOBER 2002.
- [5]. Shengming Li and Longya Xu, "Fault-Tolerant Operation of a 150KW 3-Level Neutral-Point-Clamped PWM Inverter in a Flywheel Energy Storage System", The Ohio State University, 0-7803-7116-X/01/\$10.00 (C) 2001.
- [6]. The 33rd Annual Conference of the IEEE Industrial Electronics Society (IECON) Nov. 5-8, 2007, Taipei, Taiwan, "Fault Tolerant Reconfiguration System for Asymmetric Multilevel Converters Using Bi-Directional Power Switches", IEEE TRANSACTIONS ON POWER ELECTRONICS, VOL. 19, NO. 3, MAY 2004.
- [7]. "Control of Cascaded Multilevel Inverters", Keith A. Corzine, Mike W. Wielebski, Fang Z. Peng, and Jin Wang, IEEE TRANSACTIONS ON POWER ELECTRONICS, VOL. 19, NO. 3, MAY 2004.
- [8]. "Fault Detection on Multicell Converter Based on Output Voltage Frequency Analysis". P. Lezana, J. Rodríguez, R. Aguilera, C. Silva. Universidad Técnica Federico Santa María 1-4244-0136-4/06/\$20.00 '2006 IEEE.
- [9]. " Fault Detection and Reconfiguration Technique for Cascaded H-bridge 11-level Inverter Drives Operating under Faulty Condition", Chalongsak Rd. Ladkrabang Bangkok, 10530 THAILAND, 414 Ferris Hall, Knoxville, TN 37996-2100, USA, 1-4244-0645-5/07/\$20.00©2007 IEEE.
- [10]. "Modeling Devices With Nonlinear Voltage-Current Characteristics for Harmonic Studies Task Force on Harmonics Modeling and Simulation", IEEE TRANSACTIONS ON POWER DELIVERY, VOL. 19, NO. 4, OCTOBER 2004
- [11]. "An Improved Nonlinear STATCOM Control for Electric Arc Furnace Voltage Flicker Mitigation", Atousa Yazdani, Mariesa L. Crow, and J. Guo, IEEE TRANSACTIONS ON POWER DELIVERY, VOL. 24, NO. 4, OCTOBER 2009.