



## POWER FACTOR IMPROVEMENT USING OPEN LOOP FEEDBACK STATIC VAR COMPENSATOR (SVC)

Vasudeva Naidu<sup>1</sup>, Bindu Priya<sup>2</sup>, Shruti Chauhan<sup>3</sup>,  
Tabrez Khan<sup>4</sup>, A.M Thukaram<sup>5</sup>

<sup>1,2</sup> Asst. Professor, GITAM University, E.E.E Department, Hyderabad, (India)

<sup>3,4,5</sup> Students, GITAM University, E.E.E Department, Hyderabad, (India)

### ABSTRACT

*This paper mainly design the single phase open feedback loop SVC and improve power factor of the power system using single phase loads are induction motors, arc lamps etc. These are inductive in nature and hence have low lagging power factor. The low power factor is highly undesirable as it causes an increase in current, resulting in additional losses of active power in all the elements of power system from power system down to the utilisation devices. To compensate reactive power and improve the power factor by using a static VAR compensator, it consisting converter (2-level SCR) with capacitor bank. This work deals with the performance evaluation through analytical studies and practical implementation on an existing system consisting of a distribution transformer of 1phase, 50Hz, 230V/12V capacity. The PIC controller determines firing pulse of IGBT to compensate excessive reactive power component for PF improvement*

**Keywords:** Capacitor bank, Microcontroller, Power factor, Reactive power, Static VAR compensator.

### I. INTRODUCTION

We know that power loss is taking place in our low voltage distribution systems on account of poor power factor, due to limited reactive power compensation facilities and their improper control. In rural power distribution systems in wide spread remote areas, giving rise to more inductive loads resulting in very low power factors. It is necessary to closely match reactive power with the load so as to improve power factor and reduce the losses. The voltages at remote areas are low and farmers are using high power motors operating at low load with low efficiencies. In this paper, a more reliable, fast acting and low cost scheme is presented by arranging the thyristor switched capacitor units in four binary sequential steps. . Power companies convince their customers, which are with the large loads, to increase power factors of the supply above a specified amount(0.90 or higher) or they should pay low power factor penalty. Some consumers with large loads use power factor correction schemes at their industry to avoid these penalty. The shunt capacitor improves the performance of feeder, shunt capacitor reduces voltage drop in the

feeder & transformer. It provide better voltage at load end, improves power factor. It improves system security with enhanced utilization of transformer capacity, increases over all efficiency. It saves energy due to reduced system losses, avoids low power factor penalty, and reduces maximum demand charges. Static Var Compensator is an automatic impedance matching device, it is designed to bring the system closer to unity power factor. SVCs are used in two main situations :a) Connected to the power system, to regulate the transmission voltage ("Transmission SVC"). b) Connected near large industrial loads, to improve power quality ("Industrial SVC"). This paper objective is design of single phase SVC and improve the power factor with different single phase loads. a static VAR compensator, it consisting converter (2-level IGBT) with capacitor bank. A static VAR compensator consisting of capacitor bank in four binary sequential steps with a thyristor (SCR) controlled reactor of smallest step size is employed in the investigative work. This work deals with the performance evaluation through analytical studies and practical implementation on an existing system consisting of a distribution transformer of 1phase, 50Hz, 1KV/230V capacity. The PIC controller determines firing pulse of SCR to compensate excessive reactive power component for PF improvement.

## II. STATIC VAR COMPENSATOR

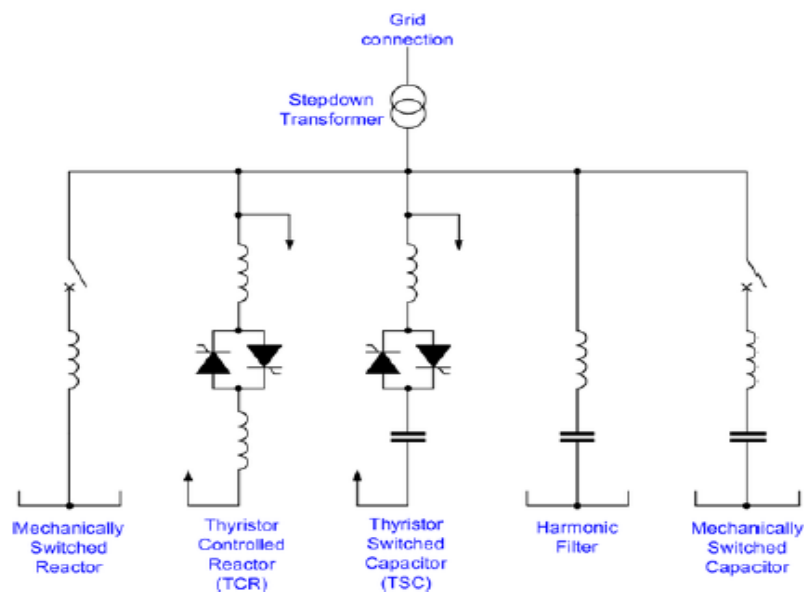

**Fig.1 A typical SVC Configuration**

It a set of electrical devices for providing fast-acting reactive power on high-voltage electricity transmission networks. SVCs are part of the Flexible AC transmission system device family, regulating voltage, power factor, harmonics and stabilizing the system. Unlike a synchronous condenser which is a rotating electrical machine, a static VAR compensator has no significant moving parts (other than internal switchgear). Prior to the invention of the SVC, power factor compensation was the preserve of large rotating machines such as synchronous condensers or switched capacitor banks. The SVC is an automated impedance matching device, designed to



bring the system closer to unity power factor. SVCs are used in two main situations: Connected to the power system, to regulate the transmission voltage ("Transmission SVC") Connected near large industrial loads, to improve power quality ("Industrial SVC") In transmission applications, the SVC is used to regulate the grid voltage. If the power system's reactive load is capacitive (leading), the SVC will use thyristor controlled reactors to consume VARs from the system, lowering the system voltage. Under inductive (lagging) conditions, the capacitor banks are automatically switched in, thus providing a higher system voltage. The figure.1. shows that one-line diagram of a typical SVC configuration; here employing a thyristor controlled reactor, a thyristor switched capacitor, a harmonic filter, a mechanically switched capacitor and a mechanically switched reactor By means of phase angle modulation switched by the thyristors, the reactor may be variably switched into the circuit and so provide a continuously variable MVAR injection (or absorption) to the electrical network. In this configuration, coarse voltage control is provided by the capacitors; the thyristor-controlled reactor is to provide smooth control. Smoother control and more flexibility can be provided with thyristor-controlled capacitor switching. The thyristors are electronically controlled. Thyristors, like all semiconductors, generate heat and deionized water is commonly used to cool them. Chopping reactive load into the circuit in this manner injects undesirable odd-order harmonics and so banks of high-power filters are usually provided to smooth the waveform. Since the filters themselves are capacitive, they also export MVARs to the power system. More complex arrangements are practical where precise voltage regulation is required. Voltage regulation is provided by means of a closed-loop controller. Remote supervisory control and manual adjustment of the voltage set-point are also common. The main advantage of SVCs over simple mechanically switched compensation schemes is their near-instantaneous response to changes in the system voltage. For this reason they are often operated at close to their zero-point in order to maximize the reactive power correction they can rapidly provide when required. They are, in general, cheaper, higher-capacity, faster and more reliable than dynamic compensation schemes such as synchronous condensers. However, static VAR compensators are more expensive than mechanically switched capacitors, so many system operators use a combination of the two technologies (sometimes in the same installation), using the static VAR compensator to provide support for fast changes and the mechanically switched capacitors to provide steady-state VARs.

### III. DESIGN OF SINGLE PHASE SVC

#### 3.1 .Design of single phase power supply

The circuit uses standard power supply comprising of a step-down transformer from 230V to 12V and 4 diodes forming a bridge rectifier that delivers pulsating dc which is then filtered by an electrolytic capacitor of about 470 $\mu$ F to 1000 $\mu$ F. The filtered dc being unregulated, IC LM7805 is used to get 5V DC constant at its pin no 3 irrespective of input DC varying from 7V to 15V. The input dc shall be varying in the event of input ac at 230volts section varies from 160V to 270V in the ratio of the transformer primary voltage V1 to secondary voltage V2 governed by the formula  $V1/V2=N1/N2$ . As  $N1/N2$  i.e. no. of turns in the primary to the no. of turns in the secondary remains unchanged V2 is directly proportional to V1. Thus if the transformer delivers 12V at 220V input it will give 8.72V at 160V. Similarly at 270V it will give 14.72V. Thus the dc voltage at the input of

the regulator changes from about 8V to 15V because of A.C voltage variation from 160V to 270V the regulator output will remain constant at 5V. The regulated 5V DC is further filtered by a small electrolytic capacitor of 10 $\mu$ F for any noise so generated by the circuit. One LED is connected of this 5V point in series with a current limiting resistor of 330 $\Omega$  to the ground i.e., negative voltage to indicate 5V power supply availability. The unregulated 12V point is used for other applications as and when required.

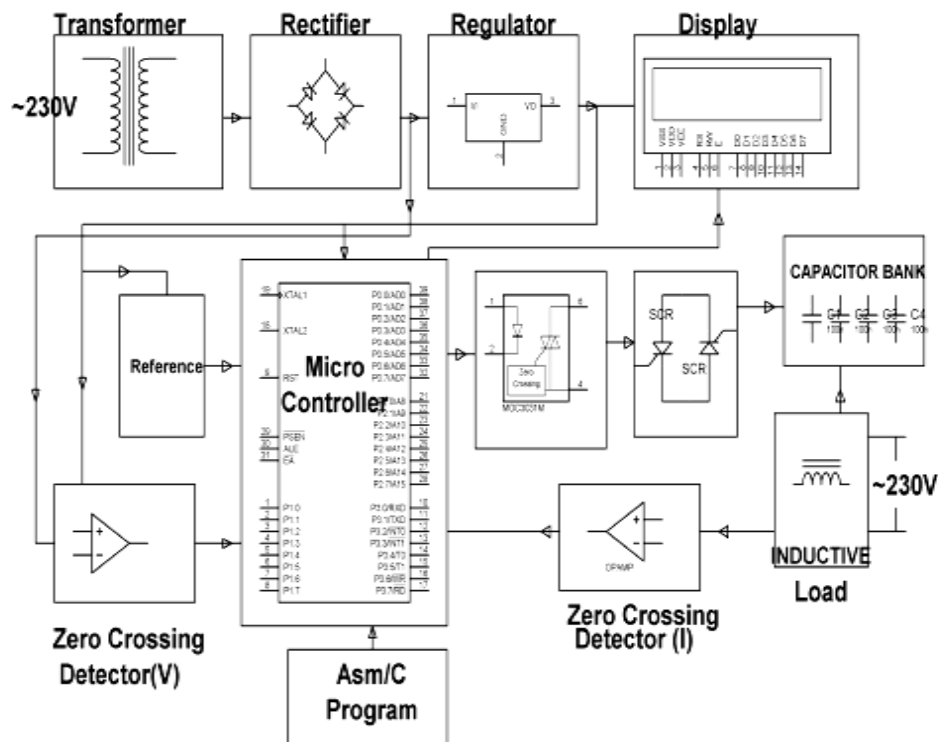
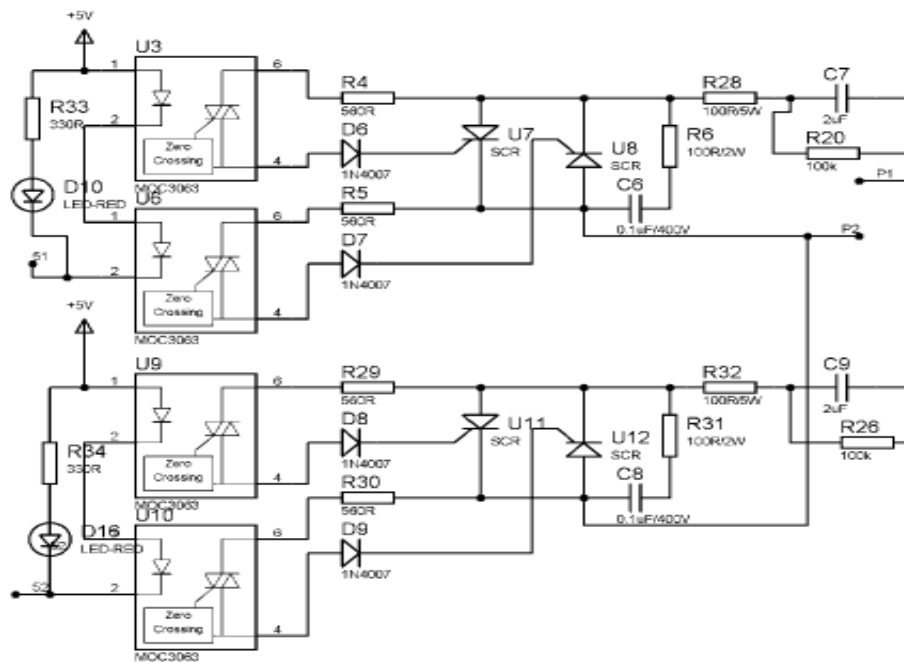

**Fig.2. Block diagram of single-phase SVC with R-L load**

### 3.2 Open loop feedback controller

In this paper controller designed using series of 8051 family of micro controllers need certain standard connections. The actual number of the Microcontroller could be “89C51”, “89C52”, “89S51”, “89S52”, and as regards to 20 pin configuration a number of “89C2051”. The 4 set of I/O ports are used based on the project requirement. Every microcontroller requires a timing reference for its internal program execution therefore an oscillator needs to be functional with a desired frequency to obtain the timing reference as  $t = 1/f$ . A crystal ranging from 2 to 20 MHz is required to be used at its pin number 18 and 19 for the internal oscillator. It may be noted here the crystal is not to be understood as crystal oscillator. It is just a crystal, while connected to the appropriate pin of the microcontroller it results in oscillator function inside the microcontroller. Typically 11.0592 MHz crystal is used in general for most of the circuits using 8051 series microcontroller. Two small value ceramic capacitors of 33pF each is used as a standard connection for the crystal as shown in the circuit diagram.

### 3.3 Switching and condition circuit



**Fig.3. Switching and converter circuit**

Potential dividers are connected to the inverting and non-inverting inputs of the op-amp to give some voltage at these terminals. Supply voltage is given to  $+V_{ss}$  and  $-V_{ss}$  is connected to ground. The output of this comparator will be logic high (i.e., supply voltage) if the non-inverting terminal input is greater than the inverting terminal input of the comparator. i.e., Non inverting input (+) > inverting input (-) = output is logic high. If the inverting terminal input is greater than the non-inverting terminal input then the output of the comparator will be logic low (i.e., gnd) i.e., inverting input (-) > Non inverting input (+) = output is logic low.

#### 3.3.1 Converter design

In this proposed paper design the 2-level SCR in anti-parallel circuit is shown in fig. it works during the positive half cycle of main current, the current flows from phase to the load through SCR. During negative half cycle flows from load side to the phase during this time another SCR comes into picture. Two SCR'S are connected back to back and are triggered from opto-isolators. MOC3063 opto-isolator is a LED-TRIAC combination. Two Opto-isolator input leds are connected in series while their output diac are used for triggering each SCR. Each 2μF capacitor such as C7 is connected in series with R28 and a pair of SCRs U7 and U8 connected in anti-parallel. A 100K resistor such as R20 is used across the 2μF capacitor to discharge it at switch off condition. R<sub>6</sub> and C<sub>6</sub> are used as a snubber network across the SCRs for inductive nature of load.

The output of power supply which is 5v is connected to the 40th pin of microcontroller and gnd to the 20th pin or pin 20 of microcontroller. P0.1 and P0.2 of microcontroller is connected to pin 6 of U6 and U10 resp. P0.5 to P0.7 of microcontroller is connected to Pin 4, 5 and 6 of LCD display. P2.0 to P2.7 of microcontroller is

connected to Pin 7 to 14 of data pins of LCD display. Port 3.2 of microcontroller is connected to output of the OP-Amp (A) LM339. Port 3.3 of microcontroller is connected to output of OP-Amp (B) LM339. DESCRIPTION OF ZVS: In order to generate ZVP (Zero crossing Voltage Pulses) first we need to step down the supply voltage to 12 V and then it is converted into pulsating D.C. Then with the help of potential divider the voltage of 3 V is taken, which is given to a comparator. The comparator generates the zero crossing pulses by comparing this pulsating D.C with a constant D.C voltage of 0.6 V which is taken across a diode. Similarly for ZVC (Zero crossing Current Pulses) the voltage drop proportional to the load current across a resistor is taken and is stepped up to generate ZVC same as above. The zero crossing pulses from a pulsating D.C are shown in the figure.

#### IV. RESULT

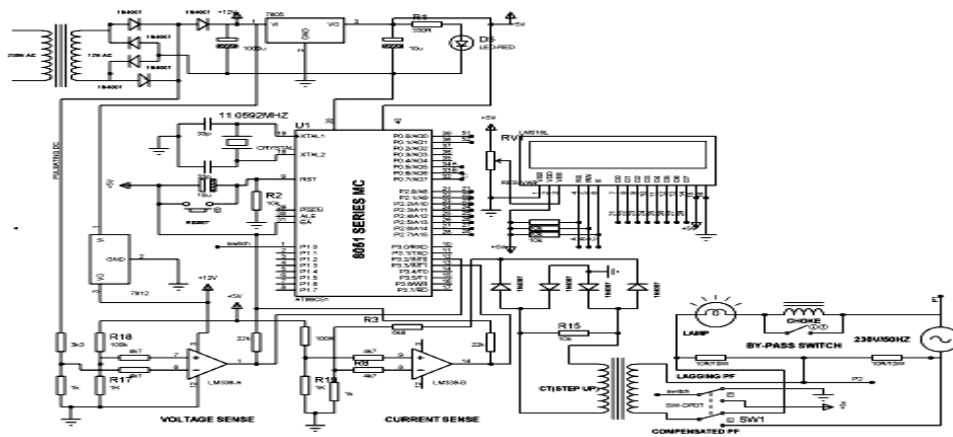

**Fig.4. Hard ware component diagram of compensated power system**

**Table.1. Hardware components and ratings**

S.NO	EQUIPMENT	NAME/RATING
1	Transformer	12V/1A
2	Voltage Regulator	IC7805
3	Rectifier (4 diodes )	IN4007
4	Filter (Capicator)	10uF
5	Micro Controller	IC8051
6	Opto Triac	ICMOC3063
7	Thyristor	TYN616
8	Quads Voltage Comparator	ICLM399
9	Current Transformer	0-12V/ 500Ma
10	Inductive load	40W,250V/0.4A
11	Shunt capicator	2MICO FARAD



This circuit consists of DC power supply unit, zero voltage crossing detectors, Micro-controller, LCD display, opto-isolator, SCR and Capacitor. Let us see how it operates. The required DC power supply for Micro-controller and other peripherals is supplied by the DC power supply. For the calculation of the power factor by the Micro-controller we need digitized voltage and current signals. The voltage signal from the mains is taken and it is converted into pulsating DC by bridge rectifier and is given to a comparator which generates the digital voltage signal. Similarly the current signal is converted into the voltage signal by taking the voltage drop of the load current across a resistor of 10 ohms. This A.C signal is again converted into the digital signal as done for the voltage signal. Then these digitized voltage and current signals are sent to the micro-controller. The microcontroller calculates the time difference between the zero crossing points of current and voltage, which is directly proportional to the power factor and it determines the range in which the power factor is. Micro-controller sends information regarding time difference between current and voltage and power factor to the LCD display to display them, Depending on the range it sends the signals to the opto-isolators that in turn switch ON back to back connected SCRs (power switches) to bring the capacitors in shunt across the load. Thus, the required numbers of capacitors are connected in parallel to the load as required. By this the power factor will be improved.

An arrangement with supply source 230v, one lamp, 2 numbers low value resistors of 10R/10W for measuring current ,a choke are all connected in series. Capacitors are required to be connected in parallel through SCR switches to improve power factor .While the by-pass switch is off, the choke acts as an inductor and same current will flow in both the 10R/10W resistors. A CT is used the primary side of which is connected to the common point of the resistors. The other point of the CT goes to the one of the common point of a DPDT S1 switch. While the DPDT switch is moved to right then the CT connects across left 10R/10W and the voltage drop proportional to the current is sensed by it to develop increased voltage at its primary. This voltage is given to the current sensing circuit. While the DPDT switch is moved to left then the CT connects across right 10R/10W and the voltage drop proportional to the current is sensed by it to develop increased voltage at its primary. While no capacitors are switched the voltage drop across both 10R/10W are same. This voltage drop is proportional to lagging current. Thus the primary voltage from the CT provides lagging current reference to the current sensing circuit. The microcontroller based control circuit thus receives zero current reference and compares with the zero voltage reference for calculating the power factor based on their time difference. Microcontroller output develops logic high for appropriate no. of port pins to feed to opto-couplers to help switching SCRs for capacitors to come in parallel to the inductive load that is the choke. So depending on the time difference required no. of SCR switches are switched on ,there by switching additional capacitors till the power factor is near unity. Once the capacitors are switched on the right 10r/10w current becomes compensated while current flowing through left 10R/10W remains unchanged which is the lagging current. Thus depending on the switch S1 position one can sense the lagging current or the compensated current and the display provides accordingly the time delay between voltage ,current with power factor display. In case a linear load is required switch by-pass is closed so that it by-passes the choke L2 and the CT in this case reads unity power factor. The other common point of the DPDT switch is goes to the MC while its switching points are connected to +ve and ground so that appropriate logic is placed on the MC for right kind of display.



A Project on Flexible AC Transmission using a Static VAR Compensator is designed and constructed and the results of the above mentioned project along with the graphs are presented here.



**Fig.5. Experimental set up of single-phase SVC**

When the model is switched on the input is a sinusoidal sine wave, taking a CRO and measuring the output waveform for the R-Load and RL-Load is connected then the wave is a lagging pf wave the following wave can be seen.

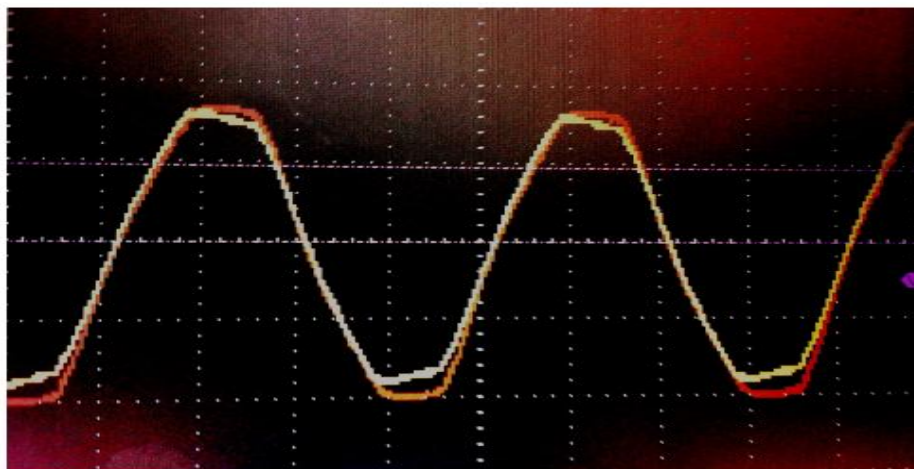

**Fig.6. voltage and current waveform without compensation with R-load**



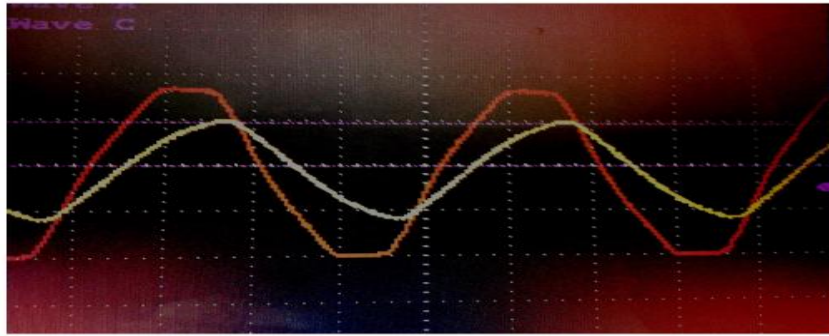

**Fig.7. voltage and current waveform without compensation with R-L-load**

When the compensator comes into action, the lagging pf is compensated and the below waveform is produced.

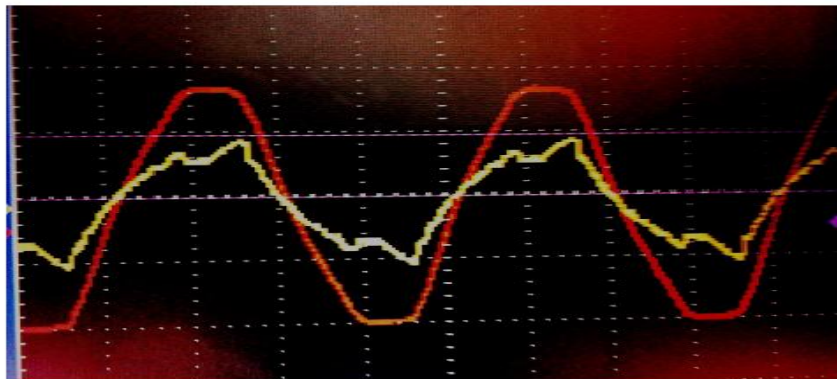

**Fig.8. voltage and current waveform after compensation**

## V .CONCLUSION

A novel Flexible AC Transmission model using SVC has been presented. The proposed paper to improve the power factor of transmission lines using SVC(Static Variable Compensator).Static VAR Compensation under FACTS uses TSC (Thyristor Switched Capacitors) based on shunt compensation duly controlled from a programmed microcontroller. Prior to the implementation of SVC, power factor compensation was done by large rotating machines such as synchronous condenser or switched capacitor banks. These were inefficient and because of large rotating parts they got damaged quickly. This proposed system demonstrates power factor compensation using thyristor switched capacitors. Further the project can be enhanced to thyristor controlled triggering for precise PF correction instead of thyristor switching in steps.

## REFERENCES

- [1] "Hardware Circuit Implementation of Static VAR Compensator (SVC) with Thyristor Binary Compensator" - Sameer U. Bagwan<sup>1</sup>, Anwar M. Mulla<sup>2</sup>, U. Gudaru<sup>3</sup>. International Electrical Engineering Journal (IEEJ) Vol. 5 (2014) No. 1, pp.1240-1246.



- [2] "PIC Microcontroller Based SVC for Reactive Power Compensation and Power Factor Correction"- Abhinav Sharma<sup>1</sup>, Vishal Nayyar<sup>2</sup>, S. Chatterji<sup>3</sup>, Ritula Thakur<sup>3</sup>, P.K. Lehana\*.International Journal of Advanced Research in Computer Science and Software Engineering, sept.2013.
- [3] "Power Factor Improvement Technique Using Static VAR Compensator (SVC)"- Miss.S.D.Arote,Visiting Faculty E&TC Dept, Govt. College of Engineering and Research Avasari Khurd, Tal:- Ambegaon, Dist:- Pune,2013.
- [4] "The Experimental Studies of Transient Free Digital SVC Controller with Thyristor Binary Compensator at 125 KVA Distribution Transformer", Dadgonda R. Patil and Uppala Gudar, IEEE Proceedings of the World Congress on Engineering 2012 Vol II, WCE 2012, July 4 - 6, 2012, London, U.K.
- [5] "LC Compensators for Power Factor Correction of Nonlinear Loads" Mohamed Mamdouh Abdel Aziz, Essam El-Din Abou El-Zahab, Ahmed Mohamed Ibrahim. IEEE transactions on power delivery, vol. 19, no. 1, january 2004
- [6] "A Static Synchronous Compensator for Displacement Power Factor Correction under Distorted Mains Voltage Conditions" -R. Cimbals, O. Krievs, L. Ribickis Faculty of Power and Electrical Engineering, Riga Technical University,Kronvalda bulv. 1- 2011
- [7] "A Small Scale Static VAR Compensator for Laboratory Experiment" -Taufikand Bryan Paet Johor Baharu, Malaysia. 2nd IEEE International Conference on Power and Energy (PECon 08), December 1-3, 2008.
- [8] "Hardware Circuit Implementation of Automatic Control of Static VAR Compensator (SVC) using Micro Controller",VenuYarlagadda,K.R.M.Rao ,B.V.Sankarram International Journal of Instrumentation, Control and Automation (IJICA) ISSN : 2231-1890 Volume-1, Issue-2,2011.
- [9] PIC microcontroller & embedded system, Mazidi, 3rd Edition, Pearson.
- [10] "Power Electronics circuits devices and applications" M. H. Rashid PHI 3rd edition, 2004, New Delhi.