



# DESIGN FPGA IMPLEMENTATION OF 4×4 MIMO OFDM TRANSCEIVER USING SYSTEM GENERATOR

Amol A. Patil<sup>1</sup>, Prof. S. R. Jajoo<sup>2</sup>

<sup>1,2</sup>*Department of Electronics & Telecommunication, Datta Meghe College of Engineering,  
Navi Mumbai, India*

## ABSTRACT

*Orthogonal Frequency Division Multiplexing (OFDM) is the most widely used modulation technique for wireless communication network. In this paper, 4 x 4 spatially multiplexed MIMO OFDM transceiver is designed using 1/2 encoder and 64 bit FFT. The implementation has been carried out in hardware using Field Programmable Gate Array (FPGA). Both the transmitter and the receiver are implemented on a single FPGA board with the channel being a wired one. The FPGA board used is Diligent Atlys Xilinx Spartan 6. We have analysed the effect of Bit Error Rate and Data rate with respect to Signal to Noise ratio.*

**Index Terms:** *OFDM, Field Programmable Gate Array (FPGA), Xilinx, Multiple Input Multiple Output, Fast Fourier Transform.*

## I. INTRODUCTION

The growth in the use of wireless networks has led to the need for new communication techniques with higher data rates. OFDM is a modulation technique used to achieve a high data rate and is able to eliminate inter-symbol interference (ISI). It is computationally efficient due to the use of Fast Fourier Transform (FFT) techniques for implementing modulation and demodulation methodology<sup>[1]</sup>.

In MIMO systems, at the expense of increased hardware and computational complexity, a high spectral efficiency can be achieved. This spectral efficiency, which can be utilized as data rate, capacity, or coverage improvement according to the needs, Multiple-input multiple-output (MIMO) technology provides extra degrees of freedom which facilitate multiplexing gains and diversity gains. Hence, MIMO has attracted a lot of research interest in the past decade since it enables significant performance enhancement without requiring additional transmit power and bandwidth resources. The combination of MIMO and OFDM is considered a viable solution for achieving these high data rates. In fact, the data rate improvement due to multiple antennas is unlimited if we allow the numbers of antennas employed at both the transmitter and the receiver to grow<sup>[2]</sup>.

## II. OFDM

In classical data systems in which more data rate was sought by exploiting the frequency domain, parallel transmissions were achieved by dividing the total signal frequency band into  $N_c$  non-overlapping frequency

sub-channels. This technique is referred to as Frequency division Multiplexing (FDM). But this method leads to inefficient use of available spectrum. A more efficient use of bandwidth can be obtained with parallel transmission if spectra of individual sub-channels are permitted to overlap. This requires specific orthogonality constraints that are imposed to facilitate separation of sub channels at the receiver. This is done using multi-carrier system, which is called as Orthogonal Frequency Division Multiplexing (OFDM).

### III. 4 X 4 MIMO SYSTEM

The 4 x 4 MIMO system is designed and implemented on a high level mathematical modelling of Matlab Simulink. The reason for selecting Matlab Simulink is because of its real time environment which resembles the real time design. The system is made of two important parts of transmitter and receiver. This is given in Fig. 4.

#### A. Spatial Multiplexing

The concept of spatial multiplexing (SM) is different from that of space- time block coding method. The SM provides high throughput as compared to STBC at higher SNR. The spatial multiplexing method uses multiple antennas at the transmitter and receiver to provide a linearly increasing capacity gain with increased number of antennas. In this system a high rate bit stream is decomposed into N independent bit sequences which are then transmitted using multiple antennas.

These signals get mixed in the channel as they use same frequency spectrum. At the receiver individual bit streams are separated, estimated and merged together to yield the original signal. Thus MIMO transmits N streams through a single channel, thereby can deliver N or more times the data rate per channel without additional bandwidth or transmit power. The 4 x 4 MIMO transceiver model in this paper implements spatial multiplexing scheme. It is given in Fig. 1

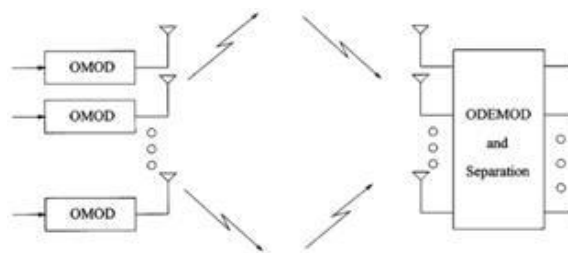

**Fig.1 OFDM-based spatial multiplexing system (OMOD and ODEMOD denote an OFDM-modulator and demodulator, respectively).**

#### B. Transmitter Section

The transmitter subsystem as in Fig. 2 mainly comprises of convolutional encoder, mapper, MIMO parser and IFFT. The sampled input voice bits are encoded using a half convolutional encoder, truncated, concatenated and is given to the mapper. The ROM\_Imaginary(ROM\_Imag), ROM\_Real altogether forms QAM mapper. The ROM\_Imag provides the value on imaginary axis while ROM\_Real provides the value on real axis giving up the points on different quadrants.

##### 1. Convolutional Encoder

The data bits are encoded using a convolutional encoder. Convolutional encoding with Viterbi decoding is a FEC technique that is particularly suited to a channel in which the transmitted signal is corrupted mainly by

additive white gaussian noise.

## 2. Mapper

According to the modes of operation the data bits are punctured and mapped with QPSK constellations mentioned as per the standard. Puncturing is the process of removing some of the parity bits. This has the same effect as encoding with an error-correction code with a higher rate, or less redundancy. Thus puncturing considerably increases the flexibility of the system without significantly increasing its complexity.

## 3. MIMO Parser

The MIMO parser performs different operations on input data bits. This operation is based on Space Time Coding (STC) or Spatial Multiplexing (SM). The multiple spatial data streams are applied to multiple interleavers. The ROM\_Imag and ROM\_Real are fed to the MIMO parser as In 1 and In 2 respectively. The main purpose of using a MIMO parser is to split the single stream input into two streams.

### C. Receiver Section

In receiver subsystem as shown in Fig. 3 the outputs of four streams from transmitter are fed as input to OFDM blocks. In OFDM1 FFT performs the exact reverse operation as that of the IFFT. It extracts the ROM\_Imag and ROM\_Real inputs for MIMO de-parser. The OFDM 2 block performs exactly same as that of OFDM 1 block and extracts the ROM\_Imag and ROM\_Real inputs for MIMO de-parser. The OFDM 3 and 4 performs exact same as that of OFDM 1 and 2 respectively to be fed as inputs for MIMO de-parser.

#### 1.MIMO De-Parser

At the transmitter side the signal is divided whereas at the receiver signals are being combined together. The combination of two or more signals is deparsering. The MIMO De-parser uses two Time Division Multiplexers. Two ROM\_Imag signals are combined to form a single ROM\_Imag1 while the two ROM\_Real signals are combined to form a single ROM\_Real signals. The output of MIMO De-parser and MIMO De-parser 1 are connected to MIMO De-parser 2 so that the splitted streams can be combined together and ROM-Imag and ROM\_Real signals can be obtained.

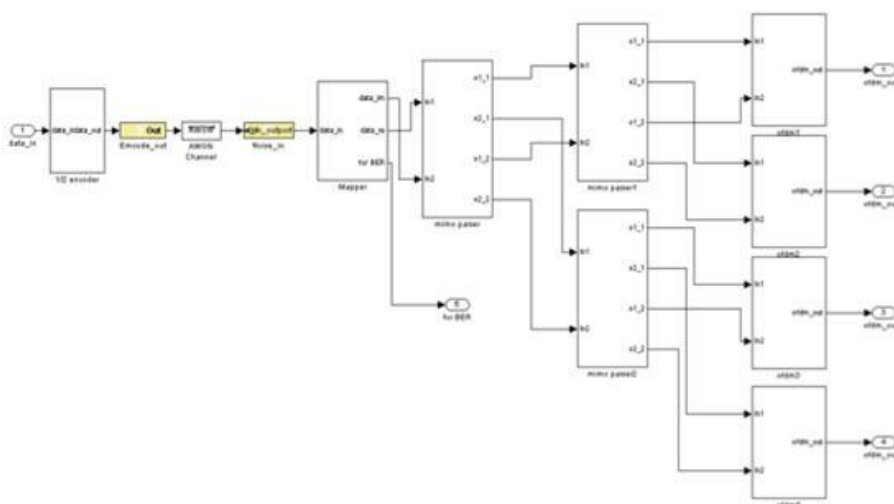

Fig 2 Transmitter Section

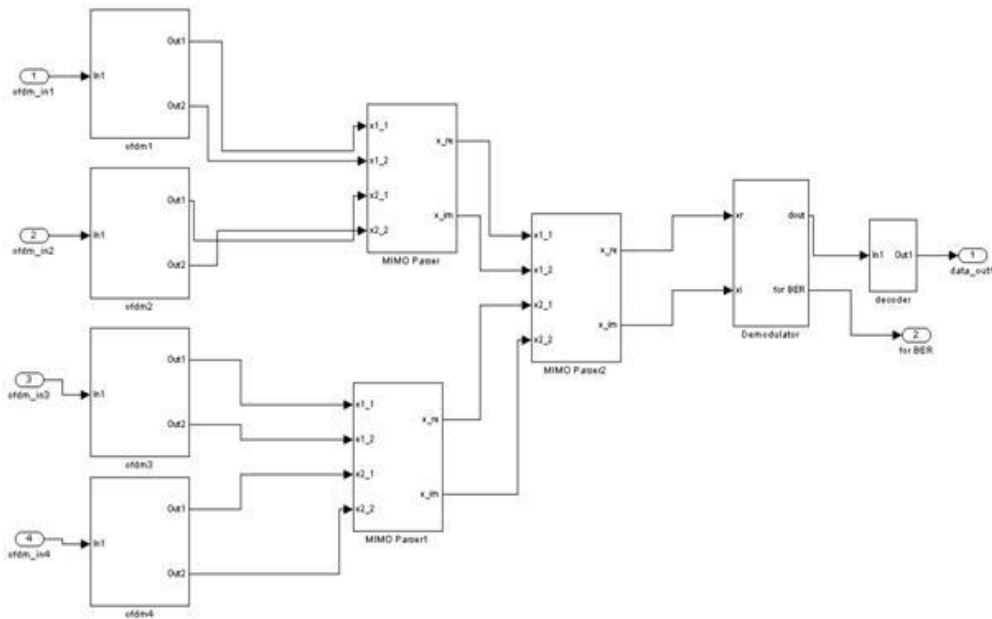

Fig. 3 Receiver Section

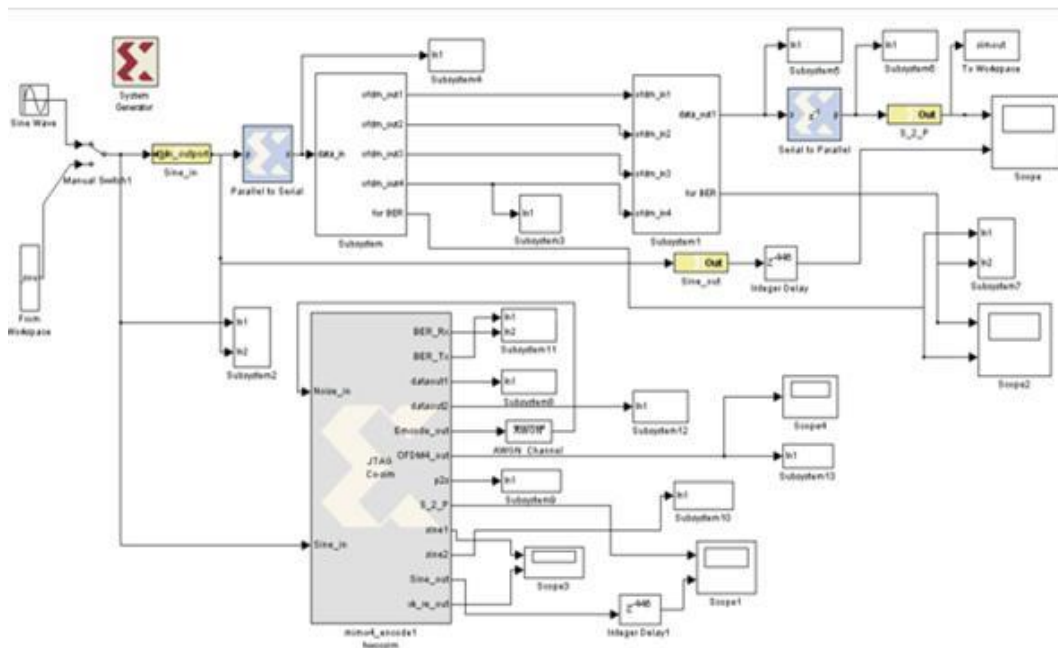

Fig. 4 MIMO-OFDM System including JTAG Co-Simulation

## IV. METHODOLOGY

Here, we used JTAG Co-Sim block to burn the bitstream file onto Spartan 6 chip. This allows us to transmit Sine wave or audio wave in FPGA board which is passed through transmitter section then receiver section and received in Simulink through “PROG” port. In Simulink we can see the original wave and received wave. hardware co-simulation, VHDL codes, RTL Schematics, Test Bench, and data rate variations are obtained for

the 4 X 4 MIMO OFDM model to verify the same.

Graphs for BER v/s SNR, Data rate v/s SNR as well as the original signal and receiver signal scope output is given in Fig. 6, Fig. 7 and Fig. 8 respectively.



Fig. 5 Atlys Digilent FPGA board

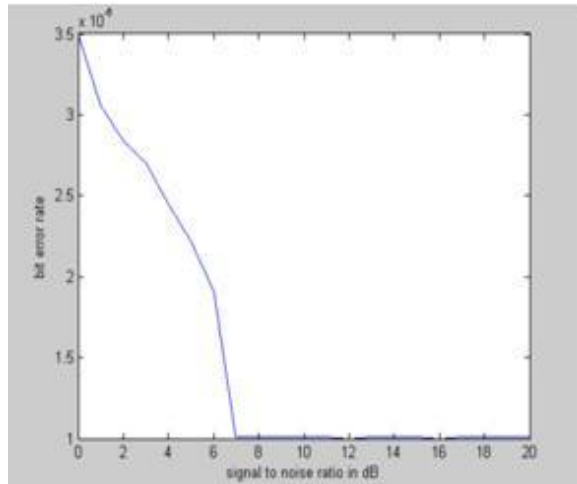

Fig. 6 BER v/s SNR(dB)

## V. RESULTS

High data rates upto 216 Mbps are achieved by transmitting large number of bits per symbol. Thus for high data rates, higher order QAM is used.

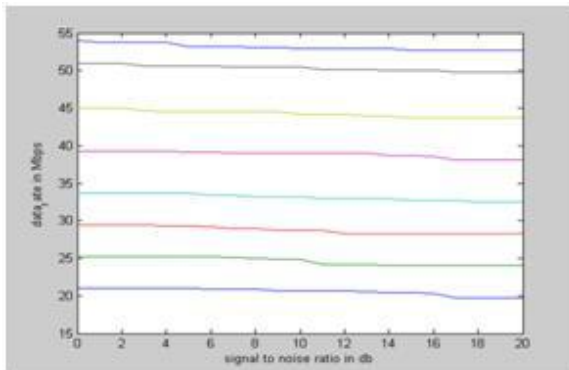

Fig.7 Data Rate v/s SNR

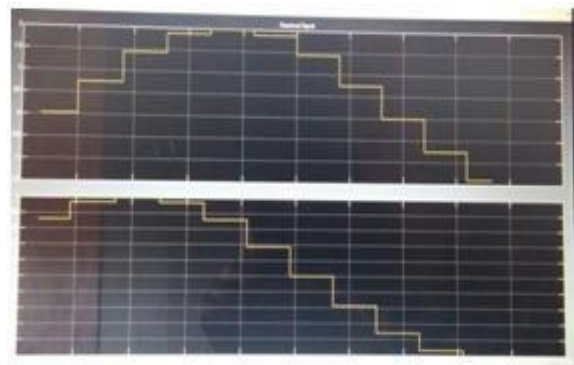

Fig 8. Original vs Received signal



Fig. 9 RTL schematic

Sr.No	Input Sampling Frequency	Transmitter Sampling frequency	Data rate from 4 channels
1	700 KHz	21 MHz	84 Mbps
2	1.3 MHz	39 MHz	132 Mbps
3	1.5 MHz	45 MHz	135 Mbps
4	1.8 MHz	54 MHz	216 Mbps

## VI. CONCLUSION

A spatially multiplexed 4 x 4 MIMO OFDM transceiver using 16 QAM was implemented on Spartan 6 FPGA board with help of Matlab Simulink, Xilinx and System Generator. As MIMO transmits four data streams through a single channel, it can deliver four or more times the data rate per channel without additional bandwidth or transmit power. Data rate up to 216 Mbps is achieved. Also there was minimum distortion between transmitted signal and received signal. The effect of Signal to Noise ratio on Data rate was very less. This can be enhanced by making a 16 x 16 MIMO system, in which data rate can be achieved in Gbps. This design can be used for upcoming 5G technology where emphasis is on both speed and reliability.

## REFERENCES

- [1]. BER Analysis with OFDM using PSK/QAM Techniques for Wireless Communication, International Journal of Engineering Research & Technology (IJERT), Vol. 1 Issue 7, September - 2012
- [2]. Performance Enhancement of MIMO-OFDMA: A Review Paper, International Journal of Computer Science and Communication Engineering, Volume 2 Issue 2 (May 2013 Issue)
- [3]. Mujtaba *et al.*, TGn Sync Proposal Tech.Specification for IEEE 802.11 Task Group 2005, IEEE 802.11-04/0889r3.
- [4]. On the Capacity of OFDM-Based Spatial Multiplexing Systems, IEEE Transaction on Communication, Vol. 50, No.2, February 2002.
- [5]. Outdoor MIMO Wireless Channels: Models and Performance Predictions, IEEE Transactions on Communication, Vol. 50, No. 12, December 2002
- [6]. Impact of the Propagation Environment on Performance of Space-Frequency Coded MIMO-OFDM, IEEE Journal on Selected Areas in Communication, Vol. 21, No. 3, April 2003.
- [7]. Ma. J. Canet, F. Vicedo, J. Valls and V. Almenar, "Design of a Digital Front-End Transmitter For OFDM-WLAN Systems Using FPGA", Control, Communications and Signal Processing 2004, First International Symposium on, pp: 503–506, 2004