



# **POWER QUALITY IMPROVEMENT IN DISTRIBUTION LINE USING DYNAMIC VOLTAGE RESTORER BASED FUZZY LOGIC CONTROLLER**

**Vasupalli.Manoj<sup>1</sup>, Shiva Prasad Nemmadi<sup>2</sup>, Desetti Veda Sagar<sup>3</sup>**

<sup>1</sup>Assistant Professor, Dept. of Power Engineering, GMR Institute of Technology, (India)

<sup>2,3</sup> UG Student, Dept. of Power Engineering, GMR Institute of Technology, (India)

## **ABSTRACT**

*One of the major concerns in electricity industry today is power quality. It becomes especially important with the introduction of advanced and complicated devices, whose performance is very sensitive to the quality of power supply. The electronic devices are very sensitive to disturbances and thus industrial loads become less tolerant to power quality problems such as voltage dips, voltage sags, voltage flickers, harmonics and load unbalance etc. At present, a wide range of very flexible controllers, which capitalize on newly available power electronics components, are emerging for custom power applications. Among these, the distribution static compensator (D-STATCOM), dynamic voltage restorer (DVR) and unified power quality conditioner (UPQC) which is based on the VSC principle are used for power quality improvement. The main aim of my paper is to design DVR which is used to compensate voltage quality problems and fuzzy logic controller is used to control the inverter. The results are compared with conventional controller. The results will be analyzed using matlab/simulink software.*

**Keywords:***Dynamic Voltage Restorer (DVR), Fuzzy Logic Controller (FLC), PI Controller, Fuzzy Inference System, Rule View, Surface View.*

## **I. INTRODUCTION**

Power quality problems in the distribution systems are interruption, voltage sag and voltage swell due to the increased use of sensitive and critical equipment's in the system. Some examples are equipment's of communication system, process industries, precise manufacturing processes etc. Power quality problems such as transients, sags, swells and other distortions to the sinusoidal waveform of the supply voltage affect the performance of these equipment's. A DVR is used to compensate the supply voltage disturbances such as sag and swell. The DVR is connected between the supply and sensitive loads, so that it can inject a voltage of required magnitude and frequency in the distribution feeder. The DVR is operated such that the load voltage magnitude is regulated to a constant magnitude, while the average real power absorbed/ supplied by it is zero in the steady state. The capacitor supported DVR is widely addressed in the literature [8-11]. The instantaneous reactive power theory (IRPT) [6], sliding mode controller [9], instantaneous symmetrical components [2] etc.,



are discussed in the literature for the control of DVR. In this project a new control algorithm is proposed based on the current mode control and proportional-integral (PI) controllers for the control of DVR. The extensive simulation is performed to demonstrate its capability, using the MATLAB with its Simulink and Power System Blockset (PSB) toolboxes.

## II. POWER QUALITY PROBLEMS

### 2.1 Introduction

“Power Quality is the concept of powering and grounding sensitive equipment in a manner that is suitable to the operation of that equipment”

#### -IEEE Std 1100

“Set of parameters defining the properties of the power supply as delivered to the user in normal operating conditions in terms of continuity of supply and characteristics of voltage”.

#### -IEC

Power quality is the combination of voltage quality and current quality. Thus power quality is concerned with deviations of voltage and/or current from the ideal. Power distribution systems, ideally, should provide their customers with an uninterrupted flow of energy at smooth sinusoidal voltage at the contracted magnitude level and frequency. However, in practice, power systems, especially the distribution systems have numerous nonlinear loads, which significantly affect the quality of power supplies. As a result of the nonlinear loads, the purity of the waveform of supplies is lost. This ends up producing many Power quality problems.

While power disturbances occur on all electrical systems, the sensitivity of today's sophisticated electronic devices makes them more susceptible to the quality of power supply. For some sensitive devices, a momentary disturbance can cause scrambled data, interrupted communications, a frozen mouse, system crashes and equipment failure etc. A power voltage spike can damage valuable components. Power Quality problems encompass a wide range of disturbances such as voltage sags/swells, flicker, harmonics distortion, impulse transient, and interruptions.

### 2.2 Power Quality Problems

- **Voltage dip:** A voltage dip is used to refer to short-term reduction in voltage of less than half a second.
- **Voltage sag:** Voltage sags can occur at any instant of time, with amplitudes ranging from 10% to 90% and duration lasting for half a cycle to one minute.
- **Voltage swell:** Voltage swell is defined as an increase in rms voltage or current at the power frequency for durations from 0.5 cycles to 1 min.
- **Voltage 'spikes', 'impulses' or 'surges':** These are terms used to describe abrupt, very brief increases in voltage value.
- **Voltage transients:** They are temporary, undesirable voltages that appear on the power supply line. Transients are high over-voltage disturbances (up to 20KV) that last for a very short time.
- **Harmonics:** The fundamental frequency of the AC electric power distribution system is 50 Hz. A harmonic frequency is any sinusoidal frequency, which is a multiple of the fundamental frequency. Harmonic frequencies can be even or odd multiples of the sinusoidal fundamental frequency.

- **Flickers:** Visual irritation and introduction of many harmonic components in the supply power and their associated ill effects.

### 2.2.1 Causes of Dips, Sags and Surges

- Rural location remote from power source.
- Unbalanced load on a three phase system.
- Switching of heavy loads.
- Long distance from a distribution transformer with interposed loads
- Unreliable grid systems.
- Equipments not suitable for local supply.

### 2.2.2 Causes of Transients and Spikes

1. Lightening.
2. Arc welding.
3. Switching on heavy or reactive equipments such as motors, transformers, motor drives.
4. Electric grade switching.

## III. DYNAMIC VOLTAGE RESTORER

### 3.1 Introduction

Among the power quality problems (sags, swells, harmonics...) voltage sags are the most severe disturbances. In order to overcome these problems the concept of custom power devices is introduced recently. One of those devices is the Dynamic Voltage Restorer (DVR), which is the most efficient and effective modern custom power device used in power distribution networks. DVR is a recently proposed series connected solid state device that injects voltage into the system in order to regulate the load side voltage. It is normally installed in a distribution system between the supply and the critical load feeder at the point of common coupling (PCC). Other than voltage sags and swells compensation, DVR can also add other features like: line voltage harmonics compensation, reduction of transients in voltage and fault current limitations.

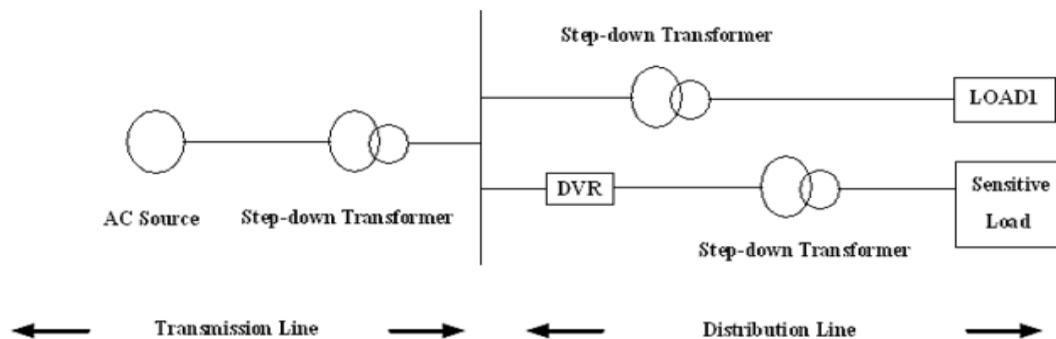

3.1 Location of DVR

### 3.2 Basic Configuration of DVR

The general configuration of the DVR consists of:

- An Injection/ Booster transformer.
- A Harmonic filter.

- A Voltage Source Converter (VSC).
- DC charging circuit.
- A Control and Protection system.

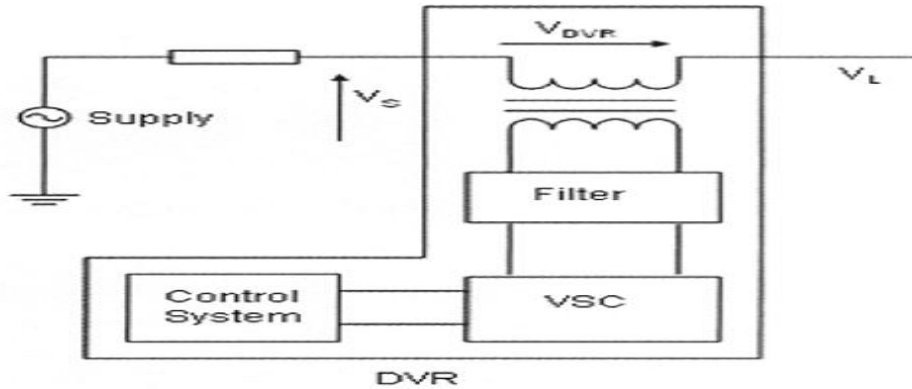

Fig 3.2 Schematic Diagram of DVR

#### IV. DVR CONTROL STRATEGY

##### 4.1 DVR Control Strategy

The proposed algorithm is based on the estimation of reference supply currents. It is similar to the algorithm for the control of a shunt compensator like DSTATCOM for the terminal voltage regulation of linear and nonlinear loads [6]. The proposed control algorithm for the control of DVR is depicted in Fig 5.1.

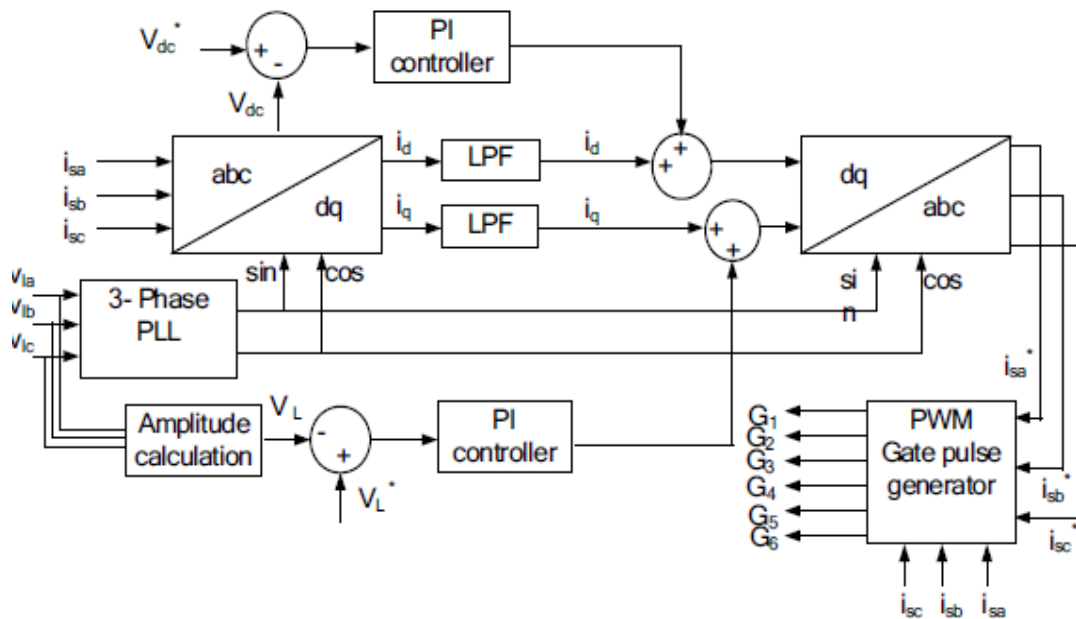

Fig 4.1 Control scheme of the DVR

The series compensator known as DVR is used to inject a voltage in series with the terminal voltage. The sag and swell in terminal voltages are compensated by controlling the DVR and the proposed algorithm inherently provides a self-supporting DC bus for the DVR. Three-phase reference supply currents ( $i_{sa}^*$ ,  $i_{sb}^*$ ,  $i_{sc}^*$ ) are derived

using the sensed load voltages ( $v_{la}$ ,  $v_{lb}$ ,  $v_{lc}$ ), terminal voltages ( $v_{ta}$ ,  $v_{tb}$ ,  $v_{tc}$ ) and dc bus voltage ( $v_{dc}$ ) of the DVR as feedback signals. The synchronous reference frame theory based method is used to obtain the direct axis ( $i_d$ ) and quadrature axis ( $i_q$ ) components of the load current. The load currents in the three-phases are converted into the d-q-0 frame using the Park's transformation as,

$$\begin{bmatrix} i_d \\ i_q \\ i_0 \end{bmatrix} = \frac{2}{3} \begin{bmatrix} \cos\theta & -\sin\theta & \frac{1}{2} \\ \cos\left(\theta - \frac{2\pi}{3}\right) & -\sin\left(\theta - \frac{2\pi}{3}\right) & \frac{1}{2} \\ \cos\left(\theta + \frac{2\pi}{3}\right) & \sin\left(\theta + \frac{2\pi}{3}\right) & \frac{1}{2} \end{bmatrix} \begin{bmatrix} i_{la} \\ i_{lb} \\ i_{lc} \end{bmatrix} \quad (4.1)$$

## V. FUZZY CONTROLLER DESIGN

### 5.1 Introduction

The main use of fuzzy control system is based on empirical rules is more effective. Fuzzy systems are easily upgraded by adding new rules or new features to improve performance. Fuzzy control can be used to improve existing traditional control systems by adding a layer of intelligence to the current control method [7]. The fuzzy logic controller consists of Fuzzy Inference System Editor. The simulation of soft switching circuit is developed in this FIS editor.  $V_{Cr}$  and  $I_{Cr}$  are the inputs of the fuzzy controller. The output of the controller is crisp value. This Graphical User Interface consists of FIS Editor, Membership function Editor, Rule Editor, Rule Viewer and Surface Viewer.

### 5.2 Fuzzy Inference Diagram

The fuzzy inference diagram is the composite of all the smaller diagrams we've been looking at so far in this section. It simultaneously displays all parts of the fuzzy inference process we've examined. Information flows through the fuzzy inference diagram. Fuzzy inference is the process of formulating the mapping from a given input to an output using fuzzy logic. The mapping then provides a basis from which decisions can be made, or patterns discerned. The process of fuzzy inference involves all of the pieces that are described in the previous sections: membership functions, fuzzy logic operators, and if-then rules.

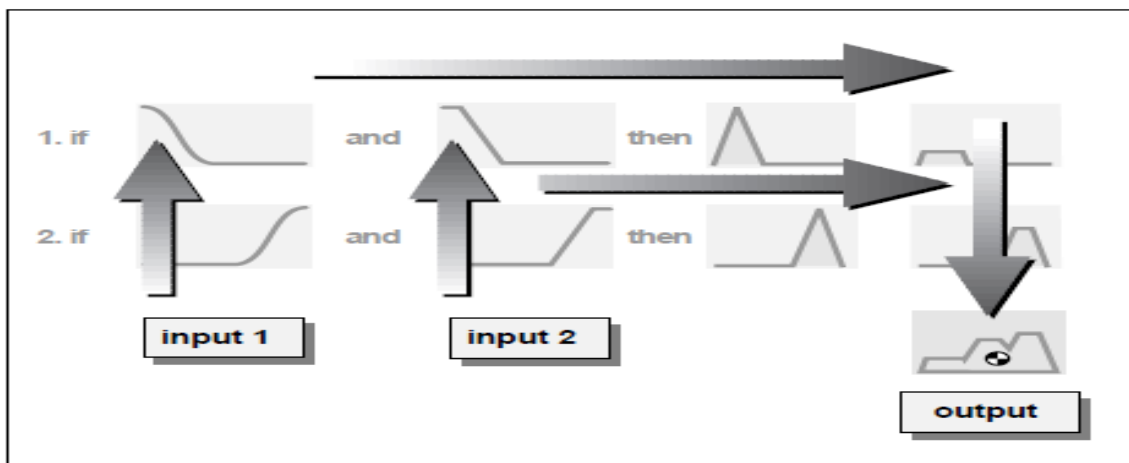
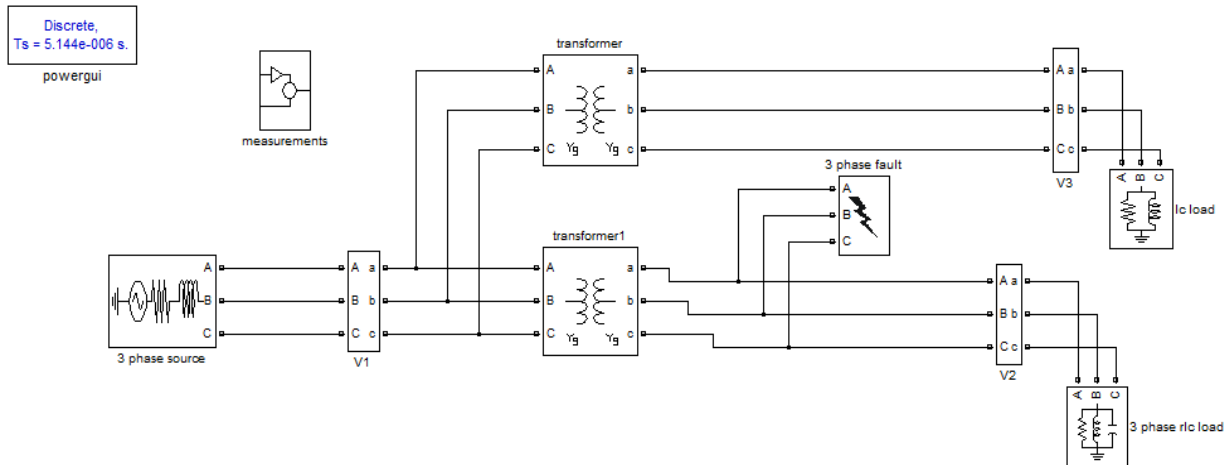

**Fig.5.1: Fuzzy Inference Diagram**

Fuzzy inference systems have been successfully applied in fields such as automatic control, data classification, decision analysis, expert systems, and computer vision. Because of its multidisciplinary nature, fuzzy inference systems are associated with a number of names, such as fuzzy-rule-based systems, fuzzy expert systems, fuzzy modeling, fuzzy associative memory, fuzzy logic controllers, and simply (and ambiguously) fuzzy systems.

**VI. SIMULATION RESULTS**

**6.1 Base System**



**Fig 6.1 Base System**

This is the block diagram showing source, load and transmission line in faulty conditions. The fault can be of any nature like L-G, L-L-G, L-L or 3-PHASE FAULT. In these conditions severe fault currents flow through the lines and there is a drastic drop in line and load voltages.

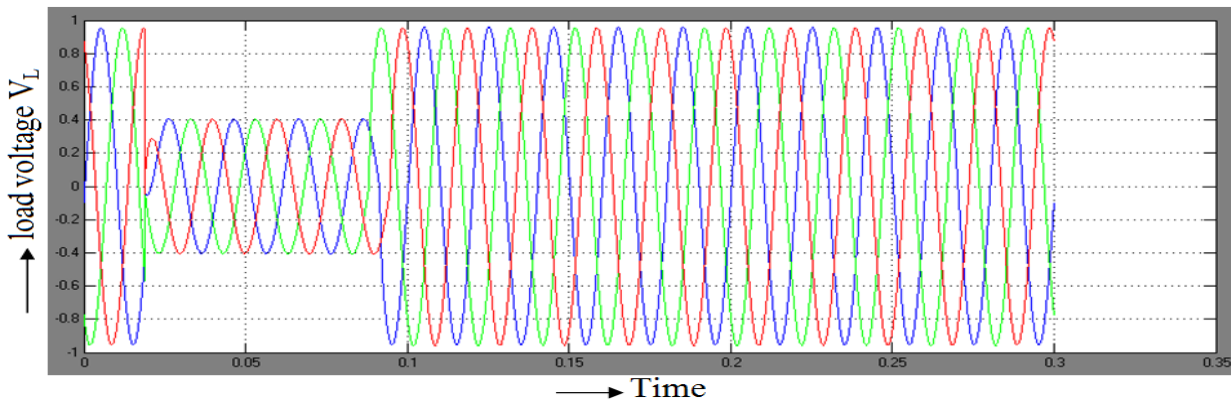

**Fig 6.2 Load Voltage**

The drop in the load voltage can be seen in above wave form due to fault in transmission line.

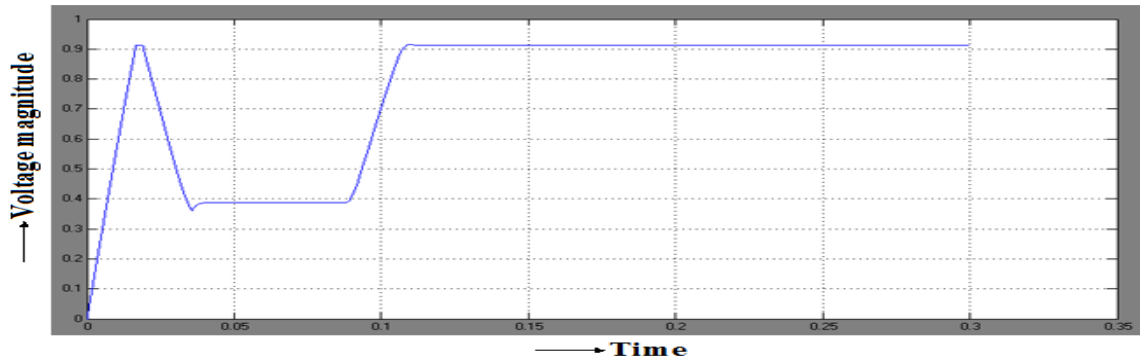

**Fig 6.3 Voltage Sag**

The sag in the voltage waveform which can be clearly observed in the above figure which is deviating from the actual voltage curve.

**6.2 Base System With PI Controller**

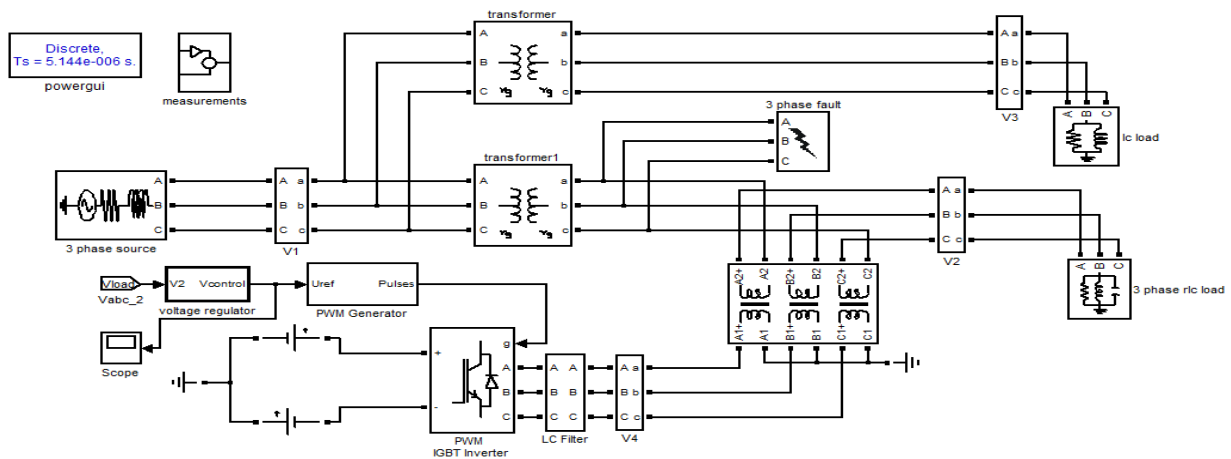

**Fig 6.4 Base System With PI Controller**

This is the block diagram showing source ,load and transmission line in faulty conditions . The type and intensity of fault can be identified and corrected with the DVR and its control mechanism . And bring back the voltage levels to the normal operating value before the occurrence of fault.

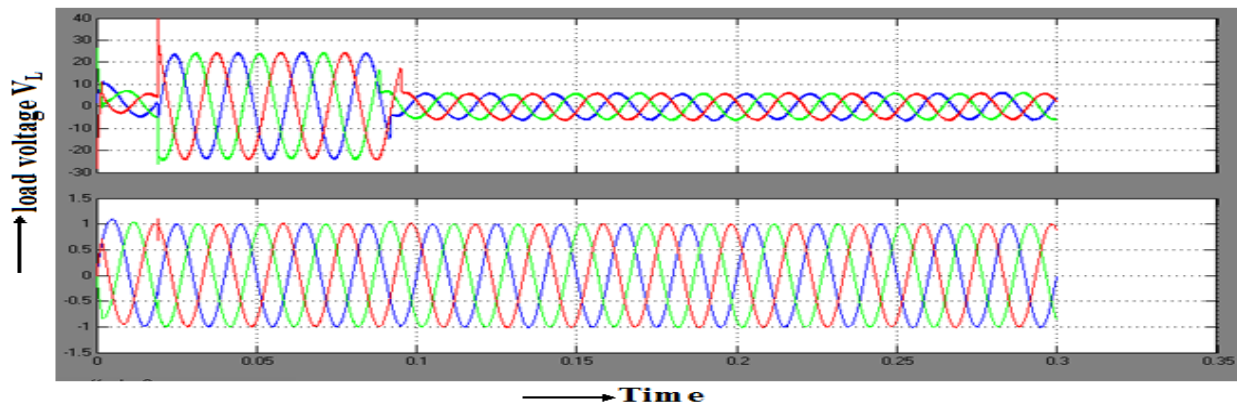

**Fig 6.5 injected voltage by the DVR**

In the above figure the first waveform implies the injected voltage by the DVR into the lines to compensate the voltage drop. The second waveform implies the compensated load voltage at the consumer side.

**6.3 Base System With Fuzzy Controller**

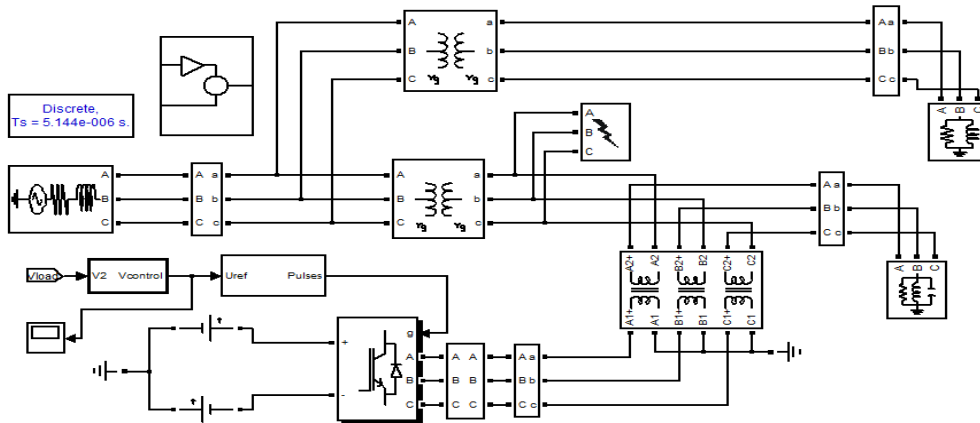

**Fig 6.6 Base System With Fuzzy Controller**

This is the block diagram showing source, load and transmission line in faulty conditions. The type and intensity of fault can be identified and corrected with the DVR and its control mechanism. And bring back the voltage levels to the normal operating value before the occurrence of fault.

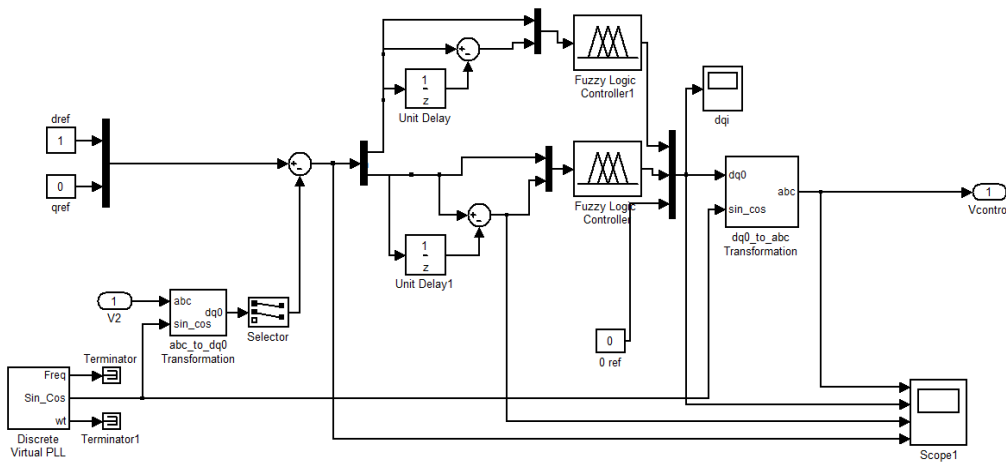

**Fig 6.7 Subsystem of Fuzzy Controller**

The controller used in the above simulation circuitry is fuzzy controller. Since fuzzy being an advanced controller there is no need of tuning the controller, hence fuzzy controller is preferred to conventional controllers.

**6.4 Design and Simulation of Fuzzy Controller**

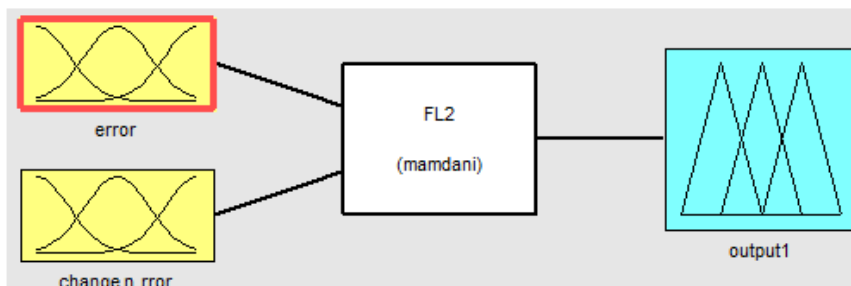

FIS editor

**Fig 6.8 FIS Editor**



FIS editor is used for giving the number of input and output variables for the fuzzy controller.

FAM table

<b>E</b> <b>DE</b>	<b>N</b>	<b>Z</b>	<b>PS</b>	<b>PFS</b>	<b>PA</b>	<b>PFB</b>	<b>PB</b>	<b>PVB</b>
<b>N</b>	N	Z	PS1	PFS1	PA1	PFB1	PB1	PVB
<b>P</b>	N	Z	PS2	PFS2	PA2	PFB2	PB2	PVB

The input and output variables are plotted in the form of membership functions with the help of FAM table only.

FAM table is a collection of statistical data regarding the system used in simulation.

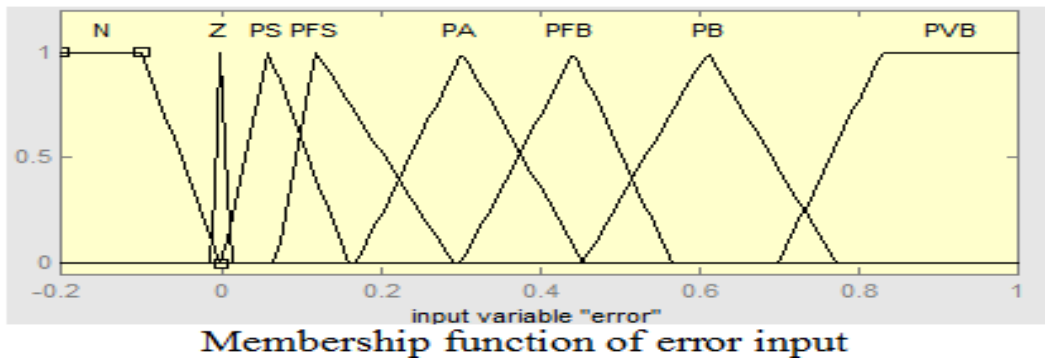

**Membership function of error input**

Fig 6.9MF of error

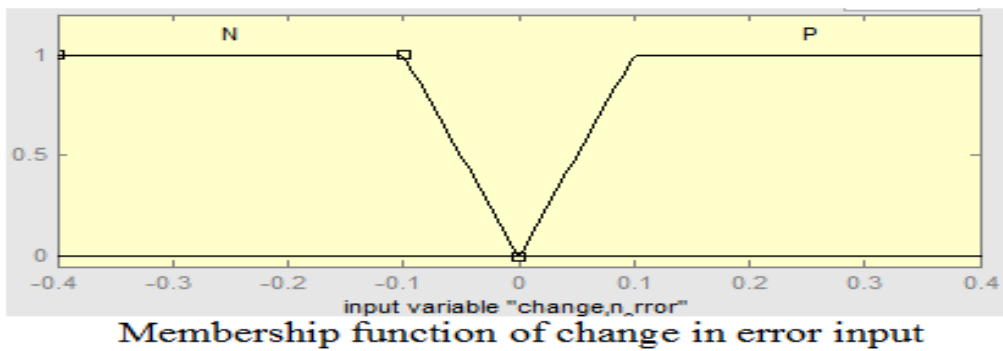

**Membership function of change in error input**

Fig 6.10MF of change in error

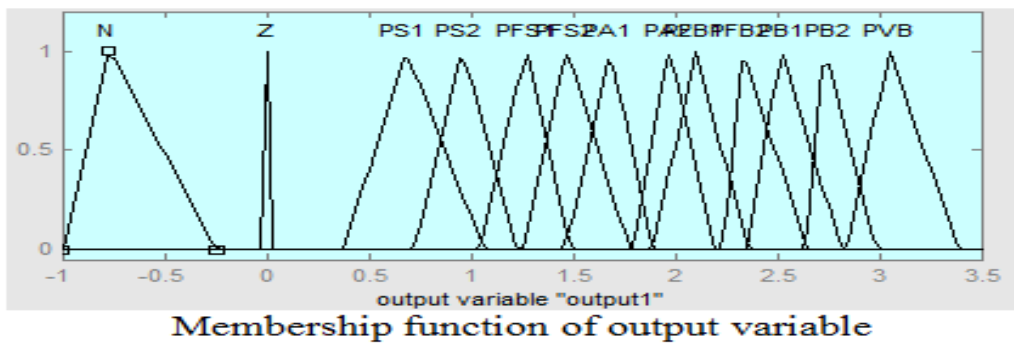

**Membership function of output variable**

Fig 6.11MF of output

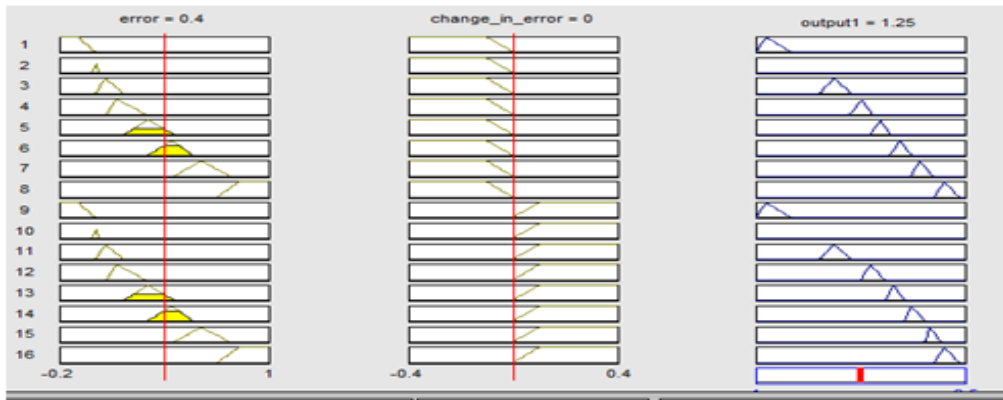

**Rule Viewer**

Fig 6.12 Rule viewer

Rule viewer is basically a window in fuzzy controller simulation to find out the optimal solution in the output comparing various input combinations as shown above.

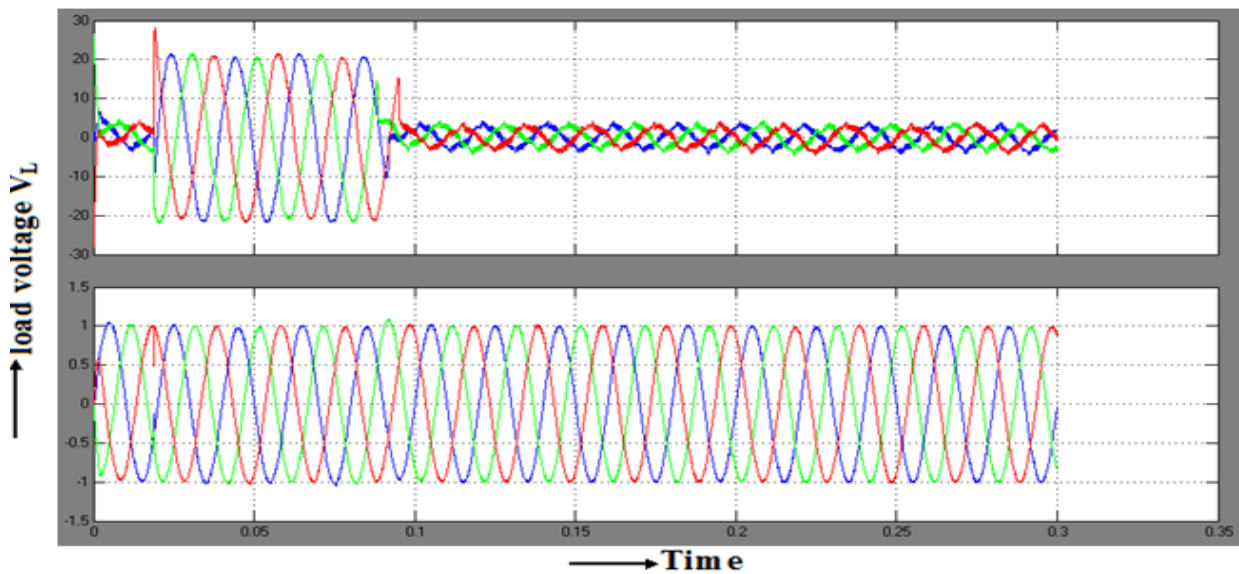

Fig 6.13 injected voltage by the DVR fuzzy

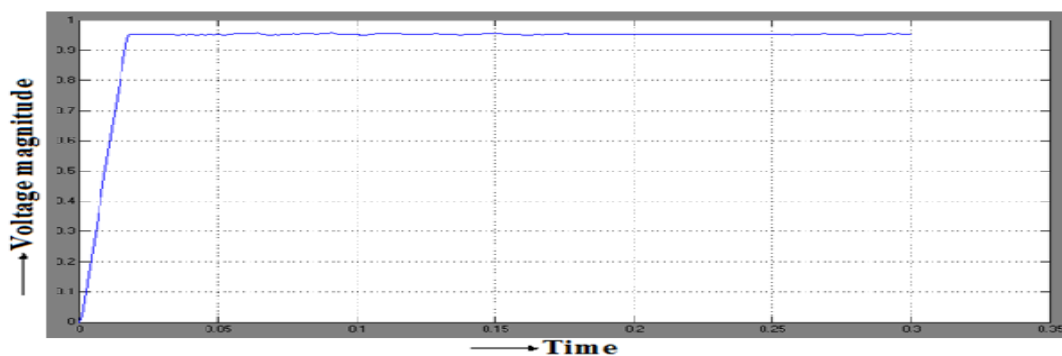
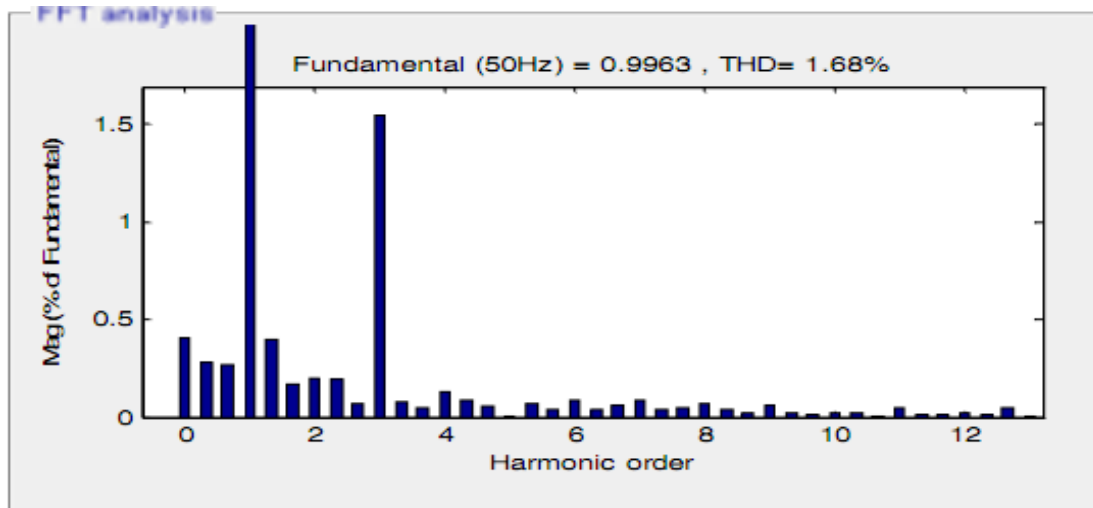

Fig 6.14 voltage sag with fuzzy

With the usage of fuzzy controller in the control circuitry of DVR we are able to eliminate the voltage drop in the lines and consumer side providing a constant voltage at the load end. This can be concluded by observing the above voltage graphs.

### 6.5 Comparison Between PI and Fuzzy Controller



**THD for PI controller**

Fig 6.15 THD with PI

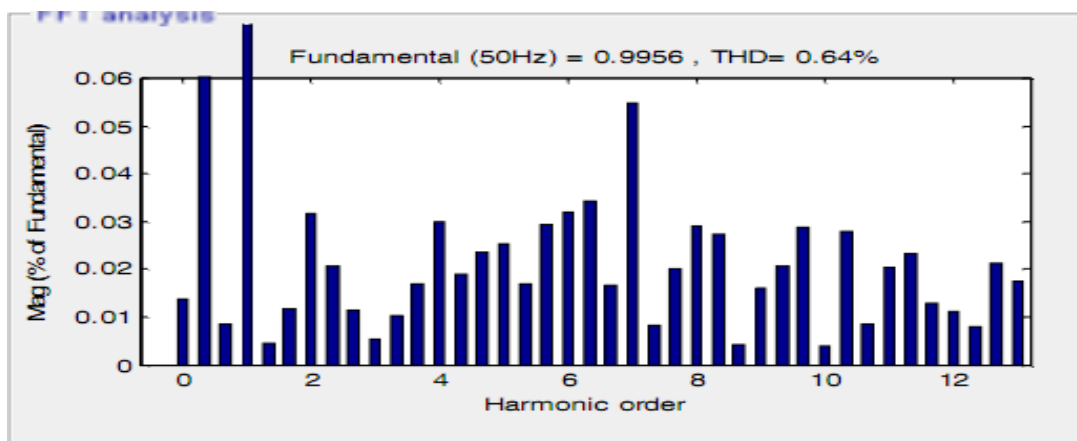

**THD for Fuzzy controller**

Fig 6.16 THD with Fuzzy

There are two controllers used for the purpose of controlling voltage drop i.e, PI and FUZZY .To suggest the best controller for serving the required purpose of voltage control the Total Harmonic Distortion (THD) of two controllers are compared. The controller with less THD is suggested as the best controller. By observing the above two figures it was definitely FUZZY controller with less THD and hence it is the best controller when compared to its counterpart.

### VII. CONCLUSION

In this study, the modeling and simulation of DVR controlled by PI and FL Controller has been developed using Matlab/Simulink. For both controller, the simulation result shows that the DVR compensates the sag quickly (70µs) and provides excellent voltage regulation. DVR handles all types, balanced and unbalanced fault without any difficulties and injects the appropriate voltage component to correct any fault situation occurred in the supply voltage to keep the load voltage balanced and constant at the nominal value. Both controllers show an excellent performance and generate low THD (<5%). However, it can be seen that FL Controller gives better



performance with THD generated with only 0.64% whilst PI generated 1.68% THD. However, other several factors that can affect the performance of DVR need to be addressed for enhancement of the output voltage. These factors are the energy storage capacity and transformer rating. From the simulation, it clearly shows the importance of these two factors and how they affect the performance of DVR. Therefore, when it comes to implementation, it is crucial to consider these factors, so that the performance of DVR is optimized.

## REFERENCES

- [1] Omar, R. Rahim, N.A. "New Control Technique Applied in Dynamic Voltage Restorer for Voltage Sag Mitigation" Industrial Electronics and Applications, 2009. ICIEA 2009.4<sup>th</sup> IEEE Conference.
- [2] Faisal, M.F. "Power Quality Management Program: TNB's Experience", Distribution Engineering, TNB 2005.
- [3] Dinesh, Lakhinana, Harish Sesham, and VasupalliManoj. "Simulation of D-Statcom with hysteresis current controller for harmonic reduction." Emerging Trends in Electrical Engineering and Energy Management (ICETEEEM), 2012 International Conference on. IEEE, 2012.
- [4] Wahab, S.W. Yusof, A.M. "Voltage Sag Mitigation Using Dynamic Voltage Restorer (DVR) System, ELEKTRIKA, 8(2),2006, 32-37.
- [5] IEEE Standard Board (1995), "IEEE Std. 1159-1995", IEEE Recommended Practice for Monitoring Electric Power Quality". IEEE Inc. New York.
- [6] Kim H. "Minimal Energy Control for a Dynamic Voltage Restorer", In proceedings of the Power Conversion Conference, Osaka, Japan, 2002, pp. 428-433.
- [7] V.K. Ramachandaramurthy, A. Arulampalam, C.Fitzer, C. Zhan, M. Barnes and N. Jenkins "Supervisory control of dynamic voltage restorers "IEE Proc.-Gener. Transm.Distrib. Vol. 151, No. 4, pp. 509- 516, July 2004.
- [8] P. Boonchiam and N. Mithulanathan, "Understanding of Dynamic Voltage Restorers through MATLAB Simulation," Thammasat Int. J. Sc. Tech., Vol. 11, No. 3, July-Sept 2006.
- [9] Nise, N. S. "Control Systems Engineering" 5<sup>th</sup> Edition, John Wiley &Son, Inc. 2008
- [10] Mattavelli, P. Rossetto, L. Spiazzi, G. Tenti, P. "General-Purpose Fuzzy Controller for DC-DC Converter" IEEE Transactions on Power Electronics, Vol. 12, No. 1, January 1997.
- [11] Nemat, M. Yousefian, H. A. Afshari, R. "Recognize The Role of A DVR in Power Systems" International Journal of Recent Trends in Engineering, Vol 2, No. 7, November 2009.
- [12] Benachaiba, C. Ferdi, B. "Voltage Quality Improvement Using DVR", Electrical Power Quality and Utilization, Journal Vol. XIV, No. 1, 2008.