

COORDINATED CONTROL OF UPFC BASED DAMPING CONTROLLER WITH PID FOR POWER SYSTEM

Amit Singhal¹, Dr. Annapurna Bhargava², Kriti Sharma³

¹PG Student [Power System] Dept. of EE, Rajasthan Technical University, Kota, Rajasthan, (India)

²Professor Dept. of EE, Rajasthan Technical University, Kota, Rajasthan, (India)

³PG Student [Power System] Dept. of EE, Vedant College of Engineering, Bundi, Rajasthan, (India)

ABSTRACT

This paper proposes an analytical approach for control designing of Unified Power Flow Controller (UPFC) for damping low frequency oscillation in a power system. we select the best input control signal of the UPFC and design optimal UPFC based damping controller in order to enhance the damping of power system. The proposed UPFC based damping controller with PID controller provides an efficient damping when compared to conventional controller. The simulations are performed in MATLAB/SIMULINK software.

Keywords: *Damping controller, PID controller, SMIB , UPFC.*

I. INTRODUCTION

The Flexible AC Transmission System (FACTS) Technology, introduced in 1988 by Hingorani in an enabling technology and provides added flexibility and can enable a line to transfer power to the thermal rating. Unified Power Flow Controller (UPFC) is one of the FACTS devices which can control three power system parameters like terminal voltage, phase angle, line impedance etc. Therefore, it can be used not only for power flow but also for the power stabilizing control. The Unified Power Flow Controller (UPFC) is one of the most commonly used FACTS devices that provides the most important performance in damping low frequency oscillations in interconnected power system [1-2].

A comprehensive and analytical approach for mathematical modeling of UPFC for steady state and linearised dynamic stability has been proposed. Several years the power system stabilizer act as a common control approach to damp the system oscillations [3]. However, in some operating conditions, the PSS may fail to stabilize the power system, especially in low frequency oscillations [4-5]. It is proved that the FACTS devices are very much effective in power flow control as well as damping out the swing of the system during fault. Among all FACTS devices the UPFC is the most popular controller for effective damping [6-7].

II. SMIB SYSTEM WITHOUT UPFC CONSIDERING FAULT

A single machine infinite bus system installed without UPFC is considered.

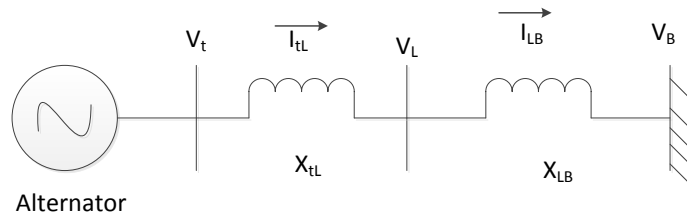

Fig.1 A single machine infinite bus system (SMIB)

$$\Delta \dot{\delta} = \omega_b \Delta \omega$$

$$\Delta \dot{\omega} = \left(-\frac{k_1}{M}\right) \Delta \delta + \left(-\frac{k_2}{M}\right) \Delta E'_q + \left(-\frac{D}{M}\right) \Delta \omega$$

$$\Delta \dot{E}'_q = \left(-\frac{k_3}{T'_{d0}}\right) \Delta \delta + \left(-\frac{k_4}{T'_{d0}}\right) \Delta E'_q + \left(\frac{1}{T'_{d0}}\right) \Delta E_{fd}$$

$$\Delta \dot{E}_{fd} = \left(-\frac{k_5 k_a}{T_a}\right) \Delta \delta + \frac{k_a}{T_a} \Delta \omega + \left(-\frac{k_6 k_a}{T_a}\right) \Delta E'_q + \left(-\frac{1}{T_a}\right) \Delta E_{fd} + \left(\frac{k_a}{T_a}\right) \Delta V_{ref}$$

With the help of these linearised equation of SMIB, we obtained a simulation model of SMIB without UPFC considering fault.

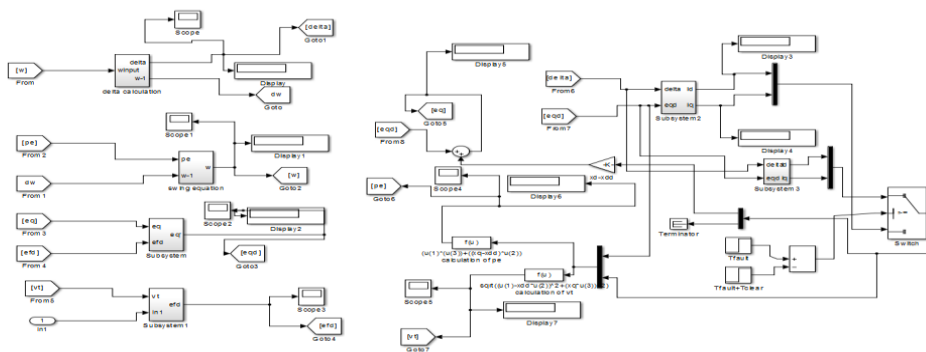
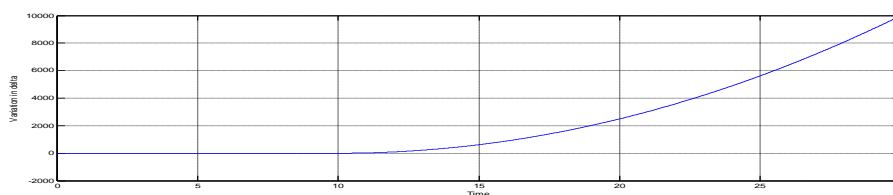

Fig.2 Simulation model of SMIB system without UPFC

The output of this simulation is taken as angle deviation, electrical power and terminal voltage .Simulation process is carried out for duration of 30 seconds.



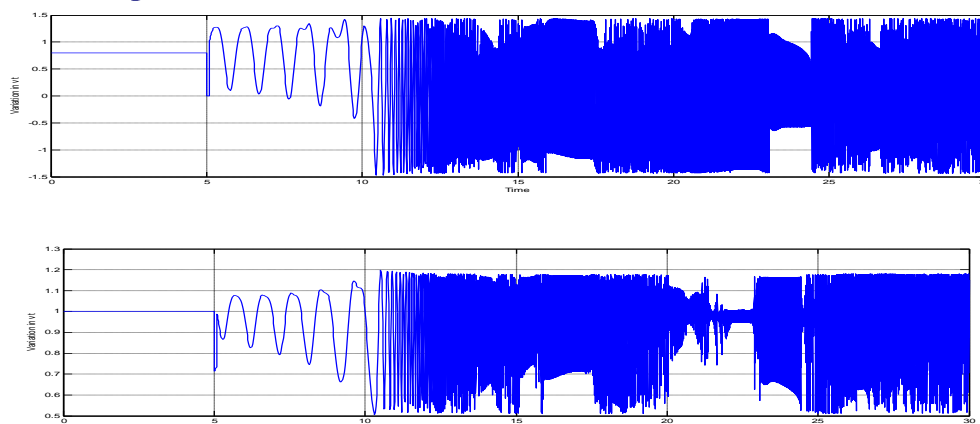

Fig.3 Response of SMIB system in Variation of load angle, electrical power , terminal voltage at 80 % loading considering fault

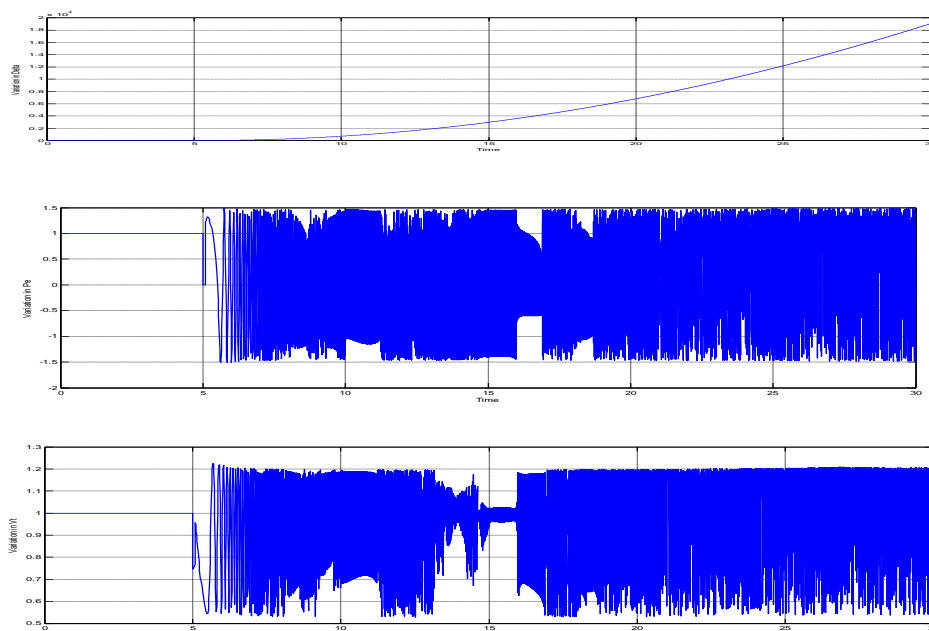

Fig.4 Response of SMIB system in Variation of load angle, electrical power , terminal voltage at 100 % loading considering fault

III. SMIB SYSTEM WITH UPFC

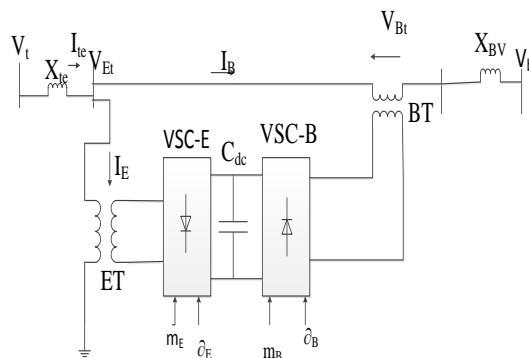

Fig.5 SMIB power system installed with UPFC

A single machine infinite bus system (SMIB) installed with UPFC as shown in fig.5. shunt converter is connected in shunt with the power system through an exciting transformer(ET) and series converter is connected in series with the power system through a boosting transformer(BT). Both transformers are connected via a dc link.

The structure of UPFC based damping controller is shown in figure

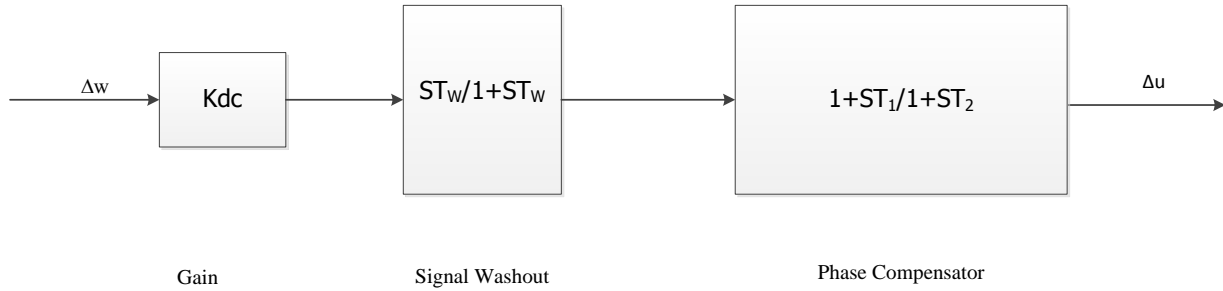

Fig.6 Structure of UPFC based damping controller

A linear dynamic model is obtained by linearizing the nonlinear model

$$\Delta \dot{\delta} = w_0 \Delta w$$

$$\Delta \dot{w} = \frac{-\Delta P_e - D \Delta w}{M}$$

$$\Delta E'_q = (-\Delta E_q + \Delta E_{fd}) / T'_{d0}$$

$$\Delta \dot{E}_{fd} = -\frac{\Delta E_{fd}}{T_a} + \frac{K_a}{T_a} (\Delta V_{ref} - \Delta V_t)$$

$$\Delta E'_q = K_4 \Delta \delta + K_3 \Delta E'_q + K_{vd} \Delta V_{dc} + K_{qe} \Delta m_E + K_{q\delta e} \Delta \delta_E + K_{qb} \Delta m_B + K_{q\delta b} \Delta \delta_B$$

$$\Delta V_t = K_5 \Delta \delta + K_6 \Delta E'_q + K_{vd} \Delta V_{dc} + K_{ve} \Delta m_E + K_{v\delta e} \Delta \delta_E + K_{vb} \Delta m_B + K_{v\delta b} \Delta \delta_B$$

$$\Delta V_{dc} = K_7 \Delta \delta + K_8 \Delta E'_q - K_9 \Delta V_{dc} + K_{ce} \Delta m_E + K_{c\delta e} \Delta \delta_E + K_{cb} \Delta m_B + K_{c\delta b} \Delta \delta_B$$

With the help of these linearised equation of SMIB with UPFC, we obtained a simulation model of SMIB with UPFC considering fault.

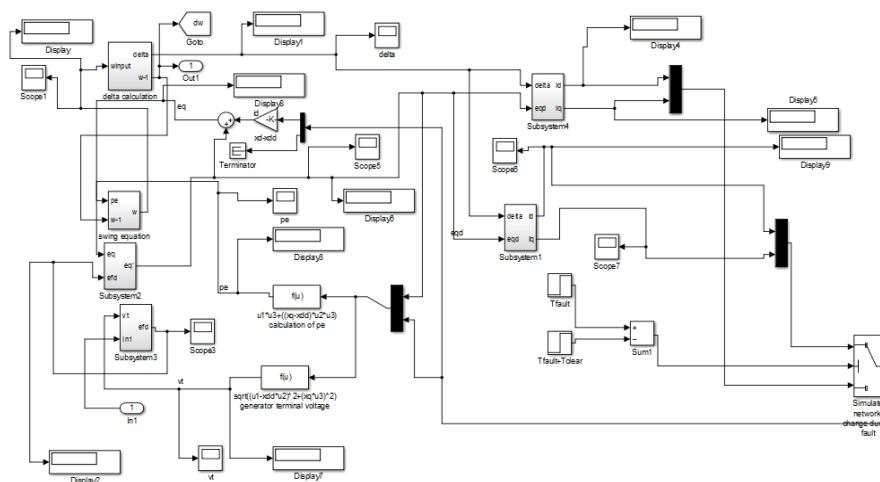

Fig.7 Simulation model of SMIB system with UPFC

The output of this simulation is taken as angle deviation, electrical power and terminal voltage .Simulation process is carried out for duration of 30 seconds.

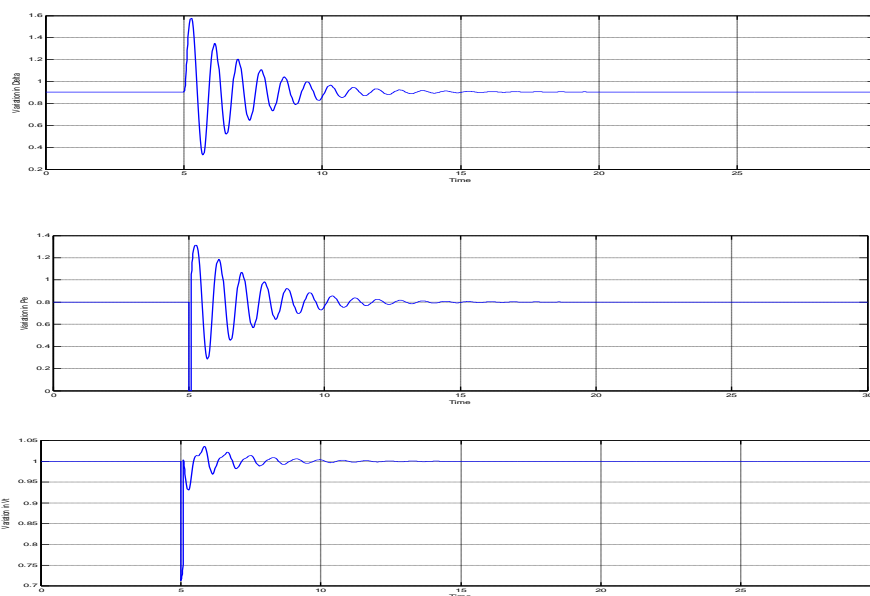
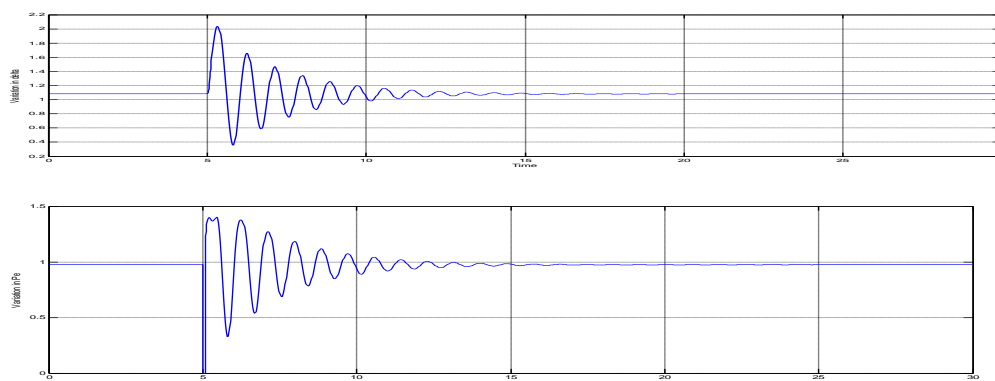

Fig.8 Response of SMIB system with UPFC in Variation of load angle, electrical power , terminal voltage at 80 % loading.



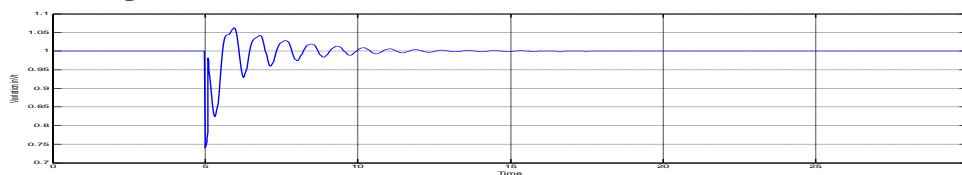

Fig.9 Response of SMIB system with UPFC in Variation of load angle, electrical power , terminal voltage at 100 % loading.

IV. SMIB SYSTEM WITH PROPOSED PID CONTROLLER FOR UPFC

As we can see that using UPFC the oscillation of SMIB is reduced. But still the system is having oscillations which should be damped. So we install a PID controller on UPFC. The input is given to PID controller is Δw and output is formed from PID controller is given as input to UPFC.

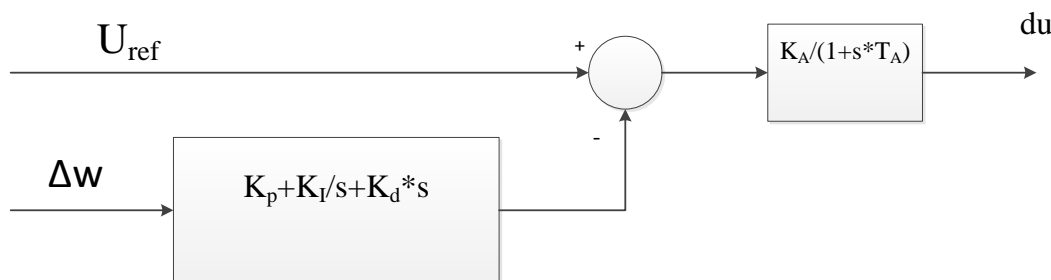

Fig.10

Structure of UPFC based damping controller with PID

The simulation model of SMIB with proposed UPFC with PID controller as shown in figure

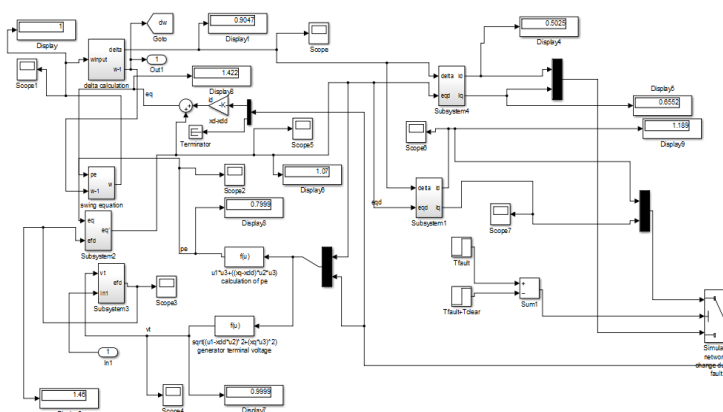

Fig.11 Simulation model of SMIB with proposed UPFC with PID controller

The output of this simulation is taken as angle deviation, electrical power and terminal voltage .Simulation process is carried out for duration of 30 seconds.

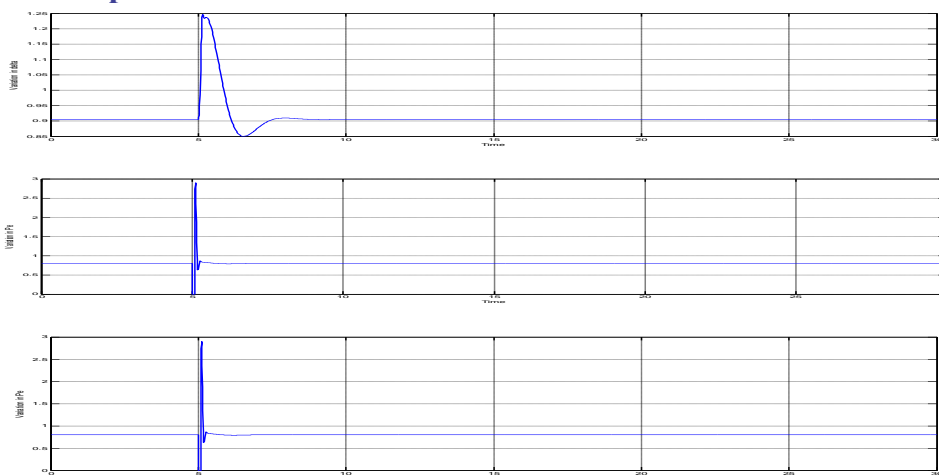

Fig.12 Response of SMIB system with proposed UPFC with PID controller in Variation of load angle, electrical power , terminal voltage at 80 % loading.

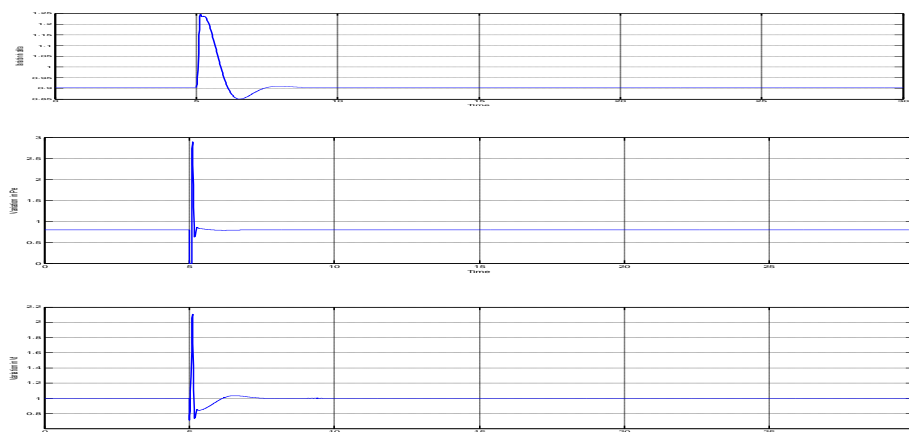

Fig.13 Response of SMIB system with proposed UPFC with PID controller in Variation of load angle, electrical power , terminal voltage at 100 % loading.

V.CONCLUSION

Objective of this work is damp the oscillation of power system using different controller. In this paper, MATLAB/SIMULINK model of a single machine infinite bus (SMIB) system with a UPFC based damping controller presented . With the help of this controller power system oscillation will damped out. But still system having the oscillation. Then we will incorporate PID controller with UPFC based damping controller. The simulation results show that UPFC with PID controller has better performance for damped out the oscillation in power system.

REFERENCES

- [1] Larsen EV, Sanchez-Gasca JJ, Chow JH. Concept for design of FACTS controllers to damp power swings. IEEE Trans PWRS 1995;10(2):948–55.

- [2] M. Noroozian, L. Angquist, M. Ghandari, and G. Anderson, "Use of UPFC for optimal power flow control", IEEE Trans. on Power Systems, vol. 12, no. 4, 1997, pp. 1629–1634
- [3] A. Nabavi-Niaki and M R Iravani. Steady-state and Dynamic Models of Unified Power Flow Controller (UPFC) for Power System Studies.' IEEE Transactions on Power Systems, vol 11, no 4, November 1996, p 1937
- [4] K. S Smith, L Ran and J Penman. 'Dynamic Modeling of a Unified Power Flow Controller.' IEE Proceedings-C, vol 144, no 1, January 1997, p 7.
- [5] H. F Wang. "Damping Function of Unified Power Flow Controller."IEE Proceedings-C, vol 146, no 1, January 1999, p 81.
- [6] H. Shayeghi , H.A. Shayanfar, S. Jalilzade and A. Safari, A PSO based unified power flow controller for damping of power system oscillations, Energy Conversion and Management, Vol. 50, 2009 pp. 2583-2592.
- [7] Kundur, P.Klein, M., Roger, G.J. and Zywno, M.S.: 'Application of power system stabilizers for enhancement of overall system stability', IEEE Trans. on Power System, 4, (2), 1989, pp. 614-626.
- [8]. Ashish Kudesia, Dr. A. M. Bisen. "FUTURE ASPECTS OF VALVELESS PULSE JET ENGINE." International Journal of Advanced Technology in Engineering and Science 3.Special Issue No. 01 (2015): 184-190.

APPENDIX

The value of parameter used in simulation are

Generator:

$M=2H=8.0, D=0, T_{do'}=5.044, X_d=1.0, X_q=0.6, X_d'=0.3$

Excitation System:

$K_A=100, T_A=0.01$

Transformer:

$X_{tE}=0.1 \text{ p.u.}, X_E=0.1 \text{ p.u.}, X_B=0.1 \text{ p.u.}$

Transmission Line:

$X_{Bv}=0.3, X_e=0.5$

Operating conditions:

$P_e=0.8, V_t=1.0 \text{ p.u.}$

$V_b=1.0 \text{ p.u.}$

UPFC parameter:

$m_E=0.4013, m_B=0.0789$

$\delta_E=-85.3478^\circ, \delta_B=-78.2174^\circ$