

# HEALTH MONITORING SYSTEM USING WIRELESS TECHNOLOGY

**Roshni A. Santani<sup>1</sup>, Mrs. Jyoti Varvadekar<sup>2</sup>**

<sup>1,2</sup>*Department of Electronics and Telecommunication Engineering*

*K. J. Somaiya College of Engineering, Mumbai (India)*

## ABSTRACT

*Different categories of patients who need physiologic monitoring like patients with a suspected life-threatening condition, patients at high risk of developing a life-threatening condition; patients in a critical physiological state .Because of these, ICUs have become widely established in hospitals. Such units use computers for the following purposes.*

*To acquire physiological data frequently & or continuously, To communicate information from data-producing systems to remote locations, To store, organize, report data, to integrate and correlate data from multiple sources, To provide clinical alerts and advisories based on multiple sources of data, To function as a decision-making tool for critically ill patients, To measure the severity of illness for patient classification purposes .To analyse the outcomes of ICU care in terms of clinical effectiveness & cost-effectiveness.*

**Keywords:** *Healthcare, wireless, Xigbee, I.C.U., I.O.T.*

## I. INTRODUCTION

Health improvement for the ICU patient is mainly based on monitoring of the patients parameters. A rapidly increasing number of health care professionals now believe that wireless technology will provide accurate data with improved patient care. A wireless telecare system is needed along the patient bedside to provide good health care. The system must be interactive. The physician is needed to send the suggestion back about the patient to the nurse so that nurse can take immediate action. In fixed monitoring systems the patient is fixed. The data is collected from patient and transmitted via different wireless modules to the server. The data is transmitted to server only when there is any abnormality exists.

Telecommunications has the potential to provide a solution to medical services to improve quality and access to health care regardless of geography. The advances in technologies enable technically, continuous monitoring of health related parameters with sensors, wherever user happens to be .We can monitor the parameters of the movable as well as fixed patient. The sensed parameters provide valuable real time information enabling the physicians to monitor and analyse a patient's current and previous state of health. The movable monitoring requires a mobile unit which is with user and also (occasionally) require a mobile unit which is with physicians. For all these a wireless link with low power capabilities is necessary. Number of wireless standards are available and can be used depending upon the requirement of design. Bluetooth is quickly becoming the preferred technology for wireless patient monitoring [5]

II. BASIC PRINCIPLE OF HEALTH CARE SYSTEMS:

The general health monitoring system, consist of different physiological (analogue) signals from sensors .Which are then converted into digital using ADC (analogue to digital converter).Then these digital outputs are given to microcontroller or to processor. The microcontroller or to processor send this data to the display system or to the printer via different connectors .or mobile unit.

2.1 Monitoring Systems

A typical medical monitoring device, such as heart-beat, glucose, body temperature, and Oxygenation monitors, have relied upon wired communication to either the local display station or network port. This setup has several detrimental faults to the safety and comfort of the patient. First, wires connected to the monitoring device present hazards to both adult and children. Wires can entangle easily with the patient creating a choking risk. They can also be walking hazards where patients may trip over the wires, or get the wires caught in various objects in their environment. Second, constant presence of wires has negative impact in the comfort of the patient. Wires can limit the movement of the patient in both active and stationary activities. They can also get in the way of medical care, where they can hinder care givers by being in their way. Lastly, the sight of large number of wires nearby the patient is very aesthetically displeasing.

A typical medical monitoring device , such as heart beat ,glucose , body temperature and oxygen monitors have relied upon wired communication to either local display station ot network port. This setup has several detrimental faults to the safety and comfort of the patient. Using Advanced Critical Response Intensive-care Bed concept, we propose to create a modularized wireless monitoring system without the need for wires from the sensor device to the main monitoring hub; we can alleviate all of the problems wires possess for patients. In this proposal, we provide the framework and possible architecture of such system.[1]

III. PROPOSED SYSTEM

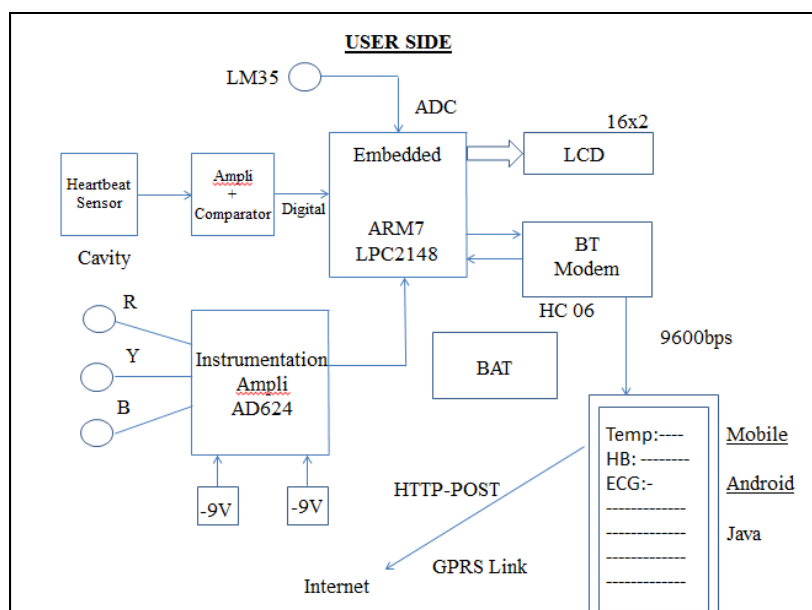

Figure 1. The proposed system

## 3.1 Sensors

### a) Heart beat sensor

As the statistics revealed earlier that Heart Attack causes the most number of deaths in the world, it was decided that have Heart Beat Monitoring as one of the Parameters.

Below it is explained as to How Heart Beat is monitored:-

- The heart beat rate of the patient is constantly monitored.
- The normal range of heart rate is 60 to 135.
- If at all the rate increases above 145 or decreases below 55, it may be fatal.
- The sensor records the data and constantly sends the parameter to patients mobile via Bluetooth.
- If the parameter(s) deviate from the standard range, it will indicate the doctor via a message consisting parameters of the patient.[6]

### b)Temperature sensor:

The normal body temperature of a person varies depending on gender, recent activity, food and fluid consumption, time of day, and, in women, the stage of the menstrual cycle. Normal body temperature can range from 97.8° F (or Fahrenheit, equivalent to 36.5° C, or Celsius) to 99° F (37.2° C) for a healthy adult.

A person's body temperature can be taken in any of the following ways:

Fever (also called pyrexia) is defined as body temperature that is higher than normal for each individual. It generally indicates that there is an abnormal process going on within the body. The severity of a condition is not necessarily reflected by the degree of fever. For example, influenza may cause a fever of 104° F, while pneumonia may cause a very low-grade fever or no fever at all. Consult with your physician if you have any questions about whether a fever is significant.[5]

There are two body temperatures that can be dangerous.

The body's normal temperature should be 37.5° C. This is the temperature at which the body can work best at. If the body temperature rises above 37.5° C this is a condition called Hyperthermia when the body absorbs more heat than it can dissipate. Temperatures above 40c are life-threatening and needs treating immediately. If the body temperature drops below 37.5c then this condition is called Hypothermia this is usually caused to excessive exposure to cold settings such as cold air and water.

It is subdivided into four different degrees, mild 32-35 °C (90-95 °F); moderate, 28-32 °C (82-90 °F); severe, 20-28 °C (68-82 °F); and profound at less than 20 °C. Medical attention is need when the body temperature drops below (32c).

### c) Electrocardiograph (ECG):

It is electrical manifestation of the contractile activity of the heart that can be recorded fast and automatically. It is non invasive diagnostic tool meaning that ECG signal can be measured without entering the body at all. Electrodes are placed at user's skin to detect bioelectric potentials given off by the heart that reach the skins surface in order to measure the rate and regularity of the heart beats, position of the chambers, the presence of any damage to the heart and show the information of the cardiovascular condition [8]

An ECG translates the heart electrical activity into line tracings on a paper.

In the medical test using ECG, the heart disease detection is based on the difference wave signal that appears on the screen during the ECG test. [7]

For ECG IC AD624AD is used, it's a precision Instrumentation Amplifier IC. It is a high precision, low noise, instrumentation amplifier which is designed primarily for use with low level transducers. Due to all these properties makes it ideal for use in high resolution data acquisition systems. Also it has an input offset voltage drift of less than  $0.25 \text{ mV}/^\circ\text{C}$ , output offset voltage drift less than  $10 \text{ mV}/^\circ\text{C}$ , Common Mode Rejection Ratio (CMRR) above 80 dB at unity gain. A 25 MHz gain bandwidth product, 5 V/ms slew rate and 15 ms settling time permit the use of AD624 in high speed data acquisition applications.[8]

#### d) ARM7 Microprocessor :

ARM7 is a generation of ARM processor designs .It is a 32-bit RISC CPU designed by ARM ARM7-TDMI (ARM7-Thumb+Debug+Multiplier+ICE) processor is a versatile processor designed for mobile devices and other low power electronics. These are based on a 32/16 bit ARM7 TDMI-S CPU with real-time emulation and embedded trace support, which combines the microcontroller with 512kB of embedded high speed Flash memory. Arm architecture is based on RISC principles ,and the instruction set and related decode mechanism are much simpler than those of CISC. This simplicity results in high instruction throughput and impressive real time interrupt response from small and cost effective processor core.

Due to their tiny size and low power consumption, these are ideal for applications where miniaturization is a key requirement, such as access control and point-of-sale. They are very well suited for communication gateways and protocol converters, soft modems, voice recognition and low end imaging, providing both large buffer size and high processing power.

Various 32-bit timers , single 10 bit ADC ,10 bit DAC , PWM channels and 45 fast GPIO lines with up to nine edge or level sensitive external interrupts pins make these microprocessors are particularly suitable for industrial control and medical systems.[4]

## IV. RESULTS

One of the results has been obtained and shown as below.The standard ECG waveform is as shown in Figure 3. The ECG waveform is called as PQRS waveform. Figure 4 shows the result of ECG sensor.

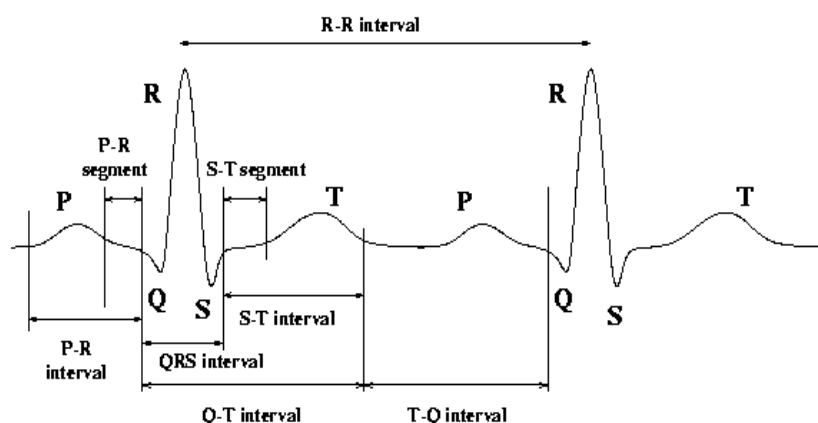

**Figure 2. PQRS waveform**

From each segment / interval of waveform the expert can detect different disease like ventricular tachycadias , fibrillation , hyperkalemia , ischemia etc.[8]. Each segment / interval that is ST,QT,PQ etc defines different

diseases. Changes that can occur in basic PQRS waveform are long QT , ST elevation ,ST depression ,T negativity , T positive,tall and peaked , long QT.

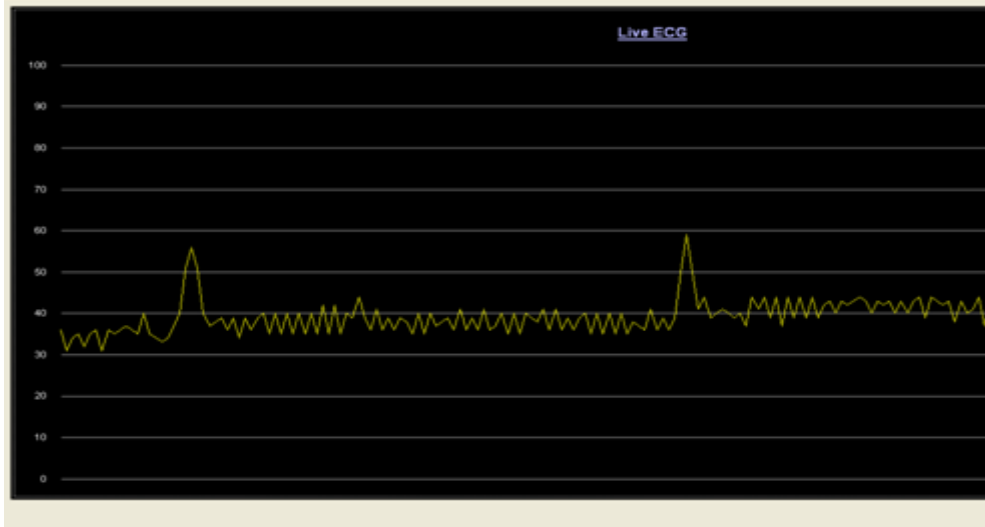

**Figure 3. Result of electrocardiograph sensor**

## V. CONCLUSION

This project started after researching a lot on the medicinal facilities available in our country. Now a day's health becomes the priority of life. When we consider ICU patient we need more and accurate care. In our country there are number of health monitoring services available but they have the limitation. Also for ICU patients we need continuous care. In this project we have given highest priority to the information which is send ON line way to the remote server via internet.

## REFERENCES

- [1] Arun E Marimuthu, Pradeep Karthikeyan "Remote patient monitoring–An implementation in ICU ward, 2011 International conference on information and network technology IPCSIT vol 4 Singapore"
- [2] <http://www.eng.tau.ac.il/~gannot/MI/file2.ppt>
- [3] Md Faizul Bari ,Rifatshahriyar ,Gourab Kundu , Sheikh Iqbal nd Md Mostofa Akbar "Intelligent Mobile Health Monitoring System, International journal of control and automation vol 2 No.3 Sept 09" by, Balgladesh university of Engg and tech.
- [4] <http://google.com>
- [5] Eindhoven Netherlands,Sidarto Bambang Oetomo, Loe Feijs "Wireless Transmission Design for Health Monitoring at Neonatal Intensive Care Unit Wei Chen1, Son Tung Nguyen1, Roland Coops. Department of Industrial Design, Eindhoven University of Technology"
- [6] Xiao yu Zhang, Hanjun Jiang, Member, IEEE, Lingwei Zhang, Chun Zhang, Zhihua Wang, Senior Member, IEEE, and Xinkai Chen IEEE TRANSACTIONS ON BIOMEDICAL CIRCUITS AND SYSTEMS, VOL. 4, NO. 1, FEB 2010 11 "An Energy-Efficient ASIC for Wireless Body Sensor Networks in Medical Applications"

- [7] C.Rodriguez, S. Borromeo, R.dela Prieta, J.A. Hernandez, and N.Mapica” Wireless ECG based Bluetooth protocol design and amplifier”
- [8] Nor hafeezah binti kamarudi, “Future extraction and classification of ECG signal to detect arrhythmia and ischemia disease” university of Malaya, may 2010