

A RESEARCH STUDY ON SOLAR PHOTOVOLTAIC MODULE FOR DIFFERENT TEMPERATURE AND WAVE LENGTH USING MATLAB SIMULATION

Praveen M Koujalgi¹, Avinash C M², Praveen A Patil³,

Rashmi J V⁴, Bharathi V⁵

^{1,2,3,4,5}*EEE Department, Rajarajeswari College of Engineering Bangalore Karnataka , (India)*

ABSTRACT

Solar system is renewable energy source. This solar energy is absorbed by Photovoltaic(PV) modules or solar cells The output of PV is the DC voltage which has to be converted into AC, hence inverter is required to converts DC input voltage to AC output voltage. In this paper the dynamic behavior of solar photovoltaic module for different temperatures and wave length are studied and simulation results are obtained using MATLAB simulation. A general mathematical expression of I-V output characteristics for PV cell has been studied. Such an equivalent circuit– based model is mainly used for maximum power point tracking (MPPT) technologies. The simulation results will be very use full in designing of inverter which can be connected to the grid The main points discussed here are the working of Photovoltaic cell and their dynamic behavior .

Keywords: MPPT , Photovoltaic(PV), MATLAB.

I. INTRODUCTION

The severe problem in many countries is the pollution and generation of energy, is the one main source of pollution. The quality of air can be very low in some areas. The more carbon dioxide we release into the atmosphere, the greater effect of air pollution, global warming and damage to the environment and ecosystem. By making the renewable energy easy to use and economically profitable, we can reduce the use of fossil fuels. One such renewable energy resource is the Photovoltaic. The Photovoltaic arrays can give us pollution free energy for industrial and domestic applications. Among the renewable energy resources, energy through the photovoltaic effect can be considered the most essential and prerequisite sustainable resource because of the ubiquity, abundance, and sustainability of solar radiant energy. Regardless of the intermittency of sunlight, solar energy is widely available and completely free of cost. Recently, photovoltaic array system is widely utilized to the forefront in electric power applications. It can generate direct current electricity without environmental impact and contamination when exposed to solar radiation. Being a semiconductor device, the photovoltaic system is static, quite, and free of moving parts, and these make it have little operation and maintenance costs. Even though the photovoltaic system is posed to its high capital fabrication cost and low conversion efficiency, skyrocketing oil prices make solar energy naturally viable energy supply with potentially long-term benefits. Sun light is composed of photon, or packet of energy. This photon contains various amount of energy corresponding to different wavelength of light, when photon strike a solar cell they may reflected or absorbed. When photon is

absorbed, energy of the photon is transferred to an electron in n atom of the cell. Electrons able to escape from its normal position associated with that atom to become part of current in an electrical circuit. The photovoltaic module represents the fundamental power conversion unit of a photovoltaic generator system. The output characteristics of photovoltaic module depends on the solar insolation, the cell temperature and output voltage of the photovoltaic module. Since photovoltaic module has nonlinear characteristics, it is necessary to model it for the design and simulation of maximum power point tracking (MPPT) for photovoltaic system applications. Almost all well-developed photovoltaic models describe the output characteristics characterized by solar insolation, cell temperature, and load voltage. Powerful component-based electronics simulation software package have becomes popular in the design and development of power electronics applications. Lot of work has been done in wind turbine models but not much in photovoltaic abundance and ease of use of solar photovoltaic motivate me to develop a generalized model for Photovoltaic cell, module, and array using MATLAB/SIMULINK

II. SIMULATION OF PV CELL AND MODULE

In this PAPER THE design and simulation of Photovoltaic cell (Solar cell) and Photovoltaic module is done in MATLAB/SIMULINK software package. A general mathematical expression of I-V output characteristics for PV cell has been studied. Such an equivalent circuit– based model is mainly used for maximum power point tracking (MPPT) technologies. The equivalent circuit of general model which consists of a photo current, a diode, a parallel resistor expressing a leakage current, and a series resistor describing an internal resistance to the current flow in figure 1.1

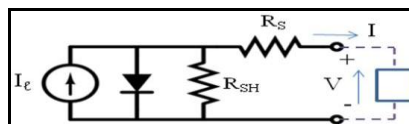

Figure 1.1: Equivalent Circuit Model for a Photovoltaic Cell

From the study it is clear that The photocurrent mainly depends on solar insolation and cell’s temperature based on this consideration calculations are obtained for single cell .The input parameters are used, which is shown in the following Table 1.1, and also calculated current and power keeping different voltage for different temperatures like 0°C and 50°C, The values of current and power are shown in the Table 1.1 to 1.3

Parameter	Variable	Value
Maximum Power	Pm	60W
Voltage at Pm	Vm	17.1V
Current at Pm	Im	3.5A
Short circuit current	ISC	2 A
Open-circuit voltage	VOC	0.5816.V
Series number of cell	Ns	1
Parallel number of cell	Np	1

Table1.1: Function block parameters of a Photovoltaic cell

Voltage	Current	Power
0.1	1.925	0.1925
0.2	1.925	0.385
0.3	1.925	0.578
0.4	1.921	0.7686
0.5	1.8333	0.9163
0.6	-0.4965	-0.2979

Table 1.2: Temperature at 0°C

.Voltage	Current	Power
0.1	2.075	0.2075
0.2	2.075	0.415
0.3	2.074	0.6225
0.4	2.06	0.824
0.5	1.84	0.9193
0.6	-1.63	-0.998

Table 1.3: Temperature at 50°C

Same equations are used for Photovoltaic module to calculate the photocurrent, reverse saturation current, cell saturation of dark current and total current. The input parameters are used, which is shown in the above table 1.1, and also calculated current and power keeping different voltage for different solar radiations like 0.2kW/m², 0.4kW/m². Values of current and power which are shown in the Table 1.4 to 1.5.

Voltage	Current	Power
5	0.7899	3.95
10	0.7878	7.878
15	0.7113	16.7
20	--1.976	-39.53
25	-96.43	-2411

Table 1.4: Solar radiation (λ) at 0.2kW/m²

Voltage	Current	Power
5	1.58	7.9
10	1.578	15.78
15	1.5	22.52
20	-1.186	-23.73
25	-95.64	-2391

Table 1.5: Solar radiation (λ) at 0.4kW/m²

III. SIMULATION RESULTS OF PHOTOVOLTAIC CELL AND MODULE

The following figure 1.2 shows the generalized Photovoltaic cell (Solar cell). From this we will get total current (I), reverse saturation current (I_{rs}), cell saturation of dark current (I_s), and power. Value of these currents is

shown in the Table 1.6 And also following figures 1.3 and 1.4 shows the reverse saturation current and cell saturation of dark current.

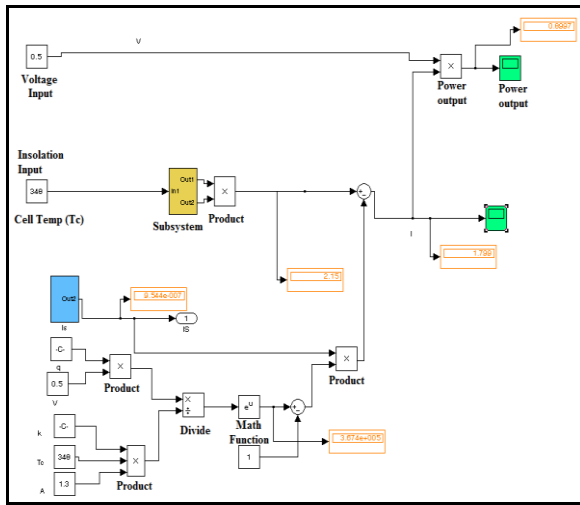

Figure 1.2: Generalized Photovoltaic cell

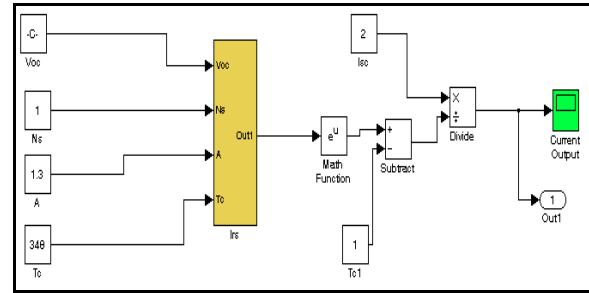

Figure 1.3: Reverse Saturation Current

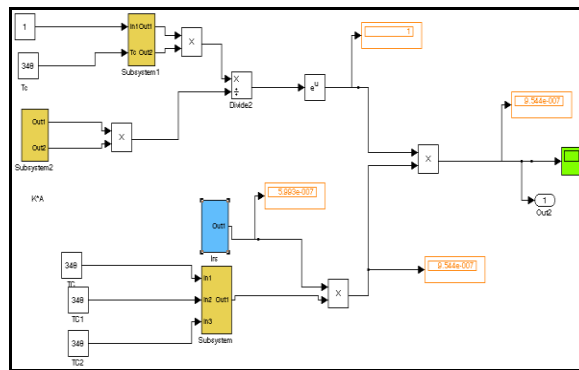

Figure 1.4: Cell Saturation Of Dark Current

Reverse saturation current (I_{rs})	5.993e-007A
Cell saturation of dark current (I_s)	9.544e-007A
Photocurrent (I_{ph})	2.15A
Total current (I)	1.8A
Power (P)	0.9W

Table 1.6: current values and power value

The following figure 1.5 shows the generalized Photovoltaic module

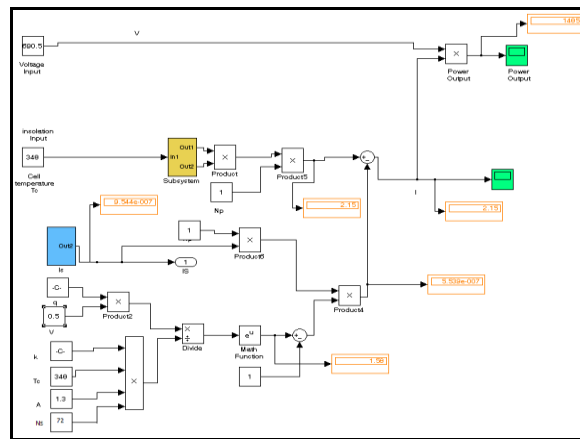

Figure 1.5: Generalized Photovoltaic Module

The following figures shows the voltage against current characteristics and power against voltage characteristics for solar cell with different temperatures and solar radiations are given in the table 1.2 and 1.3 and table 1.4 to 1.6.

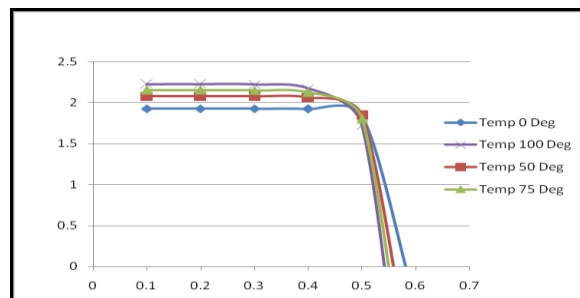

Figure :1.6 I – V output characteristic with different Tc

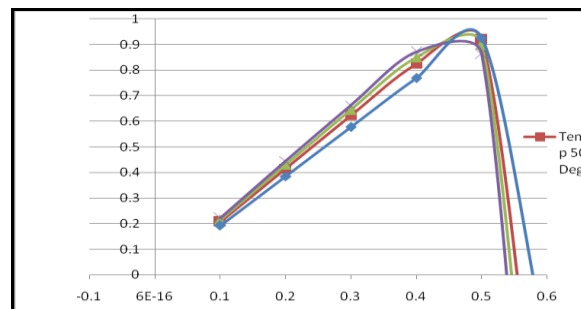

Figure 1.7: P– V output characteristic with different Tc

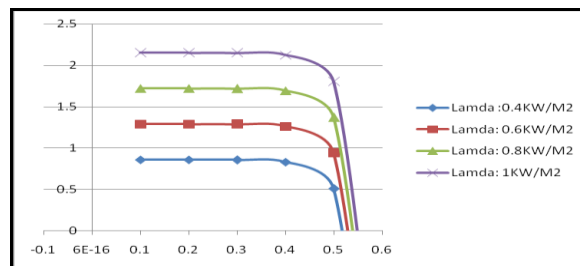

Figure 1.8: I – V output characteristic with different λ

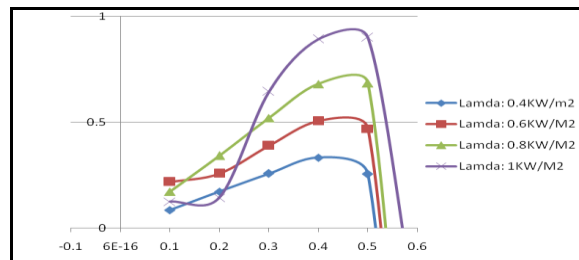

Figure 1.9:P- V output characteristic with different λ

IV. CONCLUSION

From the above simulation results it is clear that as the temperature increases the power output obtained from the PV array will be increased.

V. RESULT AND DISCUSSION

This simulation results will be very useful in the design of inverter which can be further connected to the grid

REFERANCES

- [1]. Huan – Liang Tsai, Ci – Siang Tu, and Yi – Jie Su, Member IAENG.
- [2]. K. Alafodimos¹, P. Fetfatzis^{1*}, P. Kofinas¹, M Kallousis¹, X. Kikidakis² TEI of Piraeus, Department of Automatic Controls, P. Ralli and Thivon, Aigaleo.
- [3]. S. Mekhilef and N.A. Rahim. Department of Electrical and Electronics university of Malaya, 50603, KL, Malaysia.
- [4]. M. A. A. Younis [4]. N.A. Rahim. Department of Electrical and Electronics University of Malaya, 50603, KL, Malaysia.
- [5]. Anirban Ghoshal, Dr. Vinod John. Department of Electrical Engineering Indian Institute of science (IISc)