

AMALGAMATION OF GRID CONNECTED WIND ENERGY AND SOLAR ENERGY SYSTEMS USING DISPARATE CONTROL STRATEGIES

Chinthala Praveen¹, Dr B V Sanker Ram², Dr JVB Subrahmanyam³

¹Research Scholar, JNTUH, Hyderabad (India)

²Professor, EEE Department, JNTUHCEH, Hyderabad (India)

³Professor & Principal Chritujyothi Institute of Technology & Sciences, Janagaon (India)

ABSTRACT

Wind energy and Solar energy, are considered to be the main attributes of renewable energy for electricity generation, and are growing at faster rate for the last two-three decades. This paper pertains to the study of a novel integration of wind energy from grid connected Permanent Magnet Synchronous Generator (PMSG) and solar energy systems. In order to extract maximum power from Wind energy and solar energy systems a novel technique, known as Maximum Power Point Tracking (MPPT) technique, has been adopted, in this paper. Additionally, to maintain and sustain the continuity of supply to the load on demand at all times, the outputs of wind energy and solar energy are integrated suitably. For wind generator, the overall operation is based on the estimation of the speed that is basically a sensor-less rotor speed estimator, which in fact avoids all mechanical sensors. The rotor speed so estimated, is used to control the turbine speed by maintaining the input dc quantities (Voltage and Current) for boost converter. Simulation studies of the proposed system are carried out using MATLAB / Simulink platform, and results are presented.

Keywords: Energy System, BUCK-BOOST Converter, Renewable Energy, PMG Of WECS, Photovoltaic System.

I. INTRODUCTION

With the gradual increase and continuing threat of global warming to mankind and the depletion of existing fossil fuel reserves, many countries are looking forward to sustainable green energy solutions to preserve the resources for the future generations. Other than hydro power and thermal power, wind energy and pv energy are being considered to be the preferred renewable energy, and it has the potential to meet the energy demands. Wind energy, by itself is capable to supply large amounts of power, but its existence is highly unpredictable, and depends on geographical locations and presence of tall structures. Similarly, solar energy is available throughout the day, but the solar irradiation levels vary, due to sun's intensity and unpredictable shadows cast by clouds, birds, tall buildings, trees, etc. The common drawback of wind and solar systems, are their periodic nature that make them inconsistent. Hybrid renewable energy system utilizes two or more no of energy sources, usually wind power and pv array power. The main advantage of such hybrid system is that, when these two power

sources are used together, the reliability is enhanced at load side. Often, there is presence of sun rays, while there is intense wind. However, by combining both wind and solar systems power transfer, efficiency and reliability can be improved significantly. When any of the sources is unavailable or insufficient in meeting the load demands, the other energy source can complement the deficit. Several hybrid wind and PV power systems are discussed in [2] using the conventional PI controllers for lower ratings. The proposed system consists of Wind turbine and solar PV module as inputs. Wind energy derived from PMSG, connected to grid via buck-boost converter, followed by grid side converter. To extract maximum power output, special MPPT techniques are used. In this, Hill Climbing Search (HCS) and Fuzzy Logic (FL) techniques are employed for wind energy system [1]. For solar module another MPPT technique called Perturb and Observe (P&O) is used. [3]

II. PROPOSED SYSTEM ARCHITECTURE

The block diagram of the proposed architecture is shown in Fig. 1.

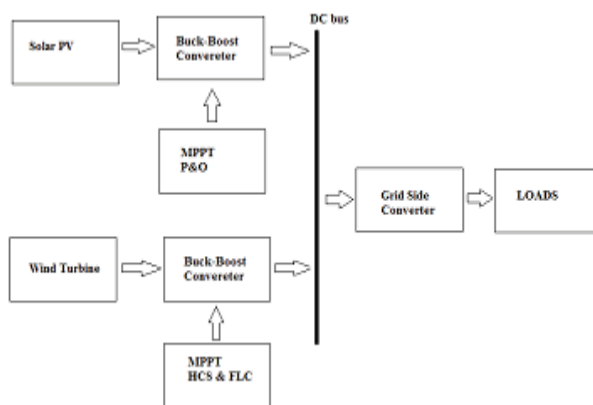

Fig.1: Block diagram of Hybrid system (consisting of WECS and Solar PV System)

Wind turbine is coupled to PMSG, which is connected to uncontrolled three phase Diode Bridge, followed by Buck- Boost converter and Grid side converter. The DC/DC converter helps to maintain fixed DC output voltage with maximized output power by controlling the gate pulses of the converter, which in-turn controlled by duty ratio of the PWM control, using MPPT technique (HCS & FL). [4]-[5] The solar photo-voltaic cell is connected to boost converter, to get high output voltage MPPT technique, Perturb and Observe (P&O) is employed to extract maximum power. And this output voltage is fed to three phase inverter voltage to AC grid voltage.

III. WIND ENERGY CONVERSION SYSTEM (WECS)

3.1 Modelling of Wind Turbine

Wind turbine converts the wind energy, extracted through blades, to mechanical energy, which in turn runs a generator to produces electrical energy. The power output of any variable speed wind turbine is given by [1],

$$P_w = \frac{1}{2} \frac{m \cdot v_w}{t} = \frac{1}{2} \frac{\rho \cdot A \cdot d \cdot v_w^2}{t} = \frac{1}{2} \rho \cdot A \cdot v_w^3 \quad (1)$$

Where P_w is wind power (W), ρ is the air density (kg/m^3), A is the area swept by the turbine blades (m^2), d is the radius of the swept area of blades (m), D is the thickness of the parcel ($D = V_m \cdot t$) (m), m is the mass of the air = air density * volume = $\rho \cdot A \cdot d$ (kg) and V_w is the wind speed (distance/time) (m/s).

The mechanical power (Pm) generated is given by,

$$P_m = P_w C_p(\lambda, \beta) = \frac{1}{2} \rho \cdot A \cdot v_w^3 \cdot C_p(\lambda, \beta) \quad (2)$$

Where Cp(λ,β) is the power coefficient function, λ is the tip speed ratio(TSR), and β is the pitch angle.

The power coefficient is given by,

$$C_p(\lambda, \beta) = C_1 \left(\frac{C_2}{\lambda_t} - C_3 \beta - C_4 \right) e^{-\frac{C_5}{\lambda_t}} + C_6 \lambda \quad (3)$$

$$\frac{1}{\lambda_t} = \frac{1}{\lambda + 0.08 \beta} - \frac{0.035}{\beta^3 + 1} \quad (4)$$

$$C_p = \frac{P_m}{P_w}; C_p < 1 \quad (5)$$

$$P_m = C_p(\lambda, \beta) \frac{\rho S}{2} v_w^3 \quad (6)$$

The generated Pm depends on Cp. Cp is the ratio of actual power delivered by the wind turbine and the theoretical power available in the wind. Cp (λ, β) depends on TSR and pitch angle β.

TSR refers to ratio of turbine angular speed to the wind speed, and is given by,

$$\lambda = \frac{d\omega}{v_w} \quad (7)$$

Where ω is the rotor speed.

The mechanical torqueTM for gearless WECS is given by,

$$T_m = P_m \frac{d}{\lambda \cdot v_w} = \frac{1}{2} \rho \cdot A \cdot C_p(\lambda, \beta) \frac{R}{v_w} = \frac{P_m}{\omega} \quad (8)$$

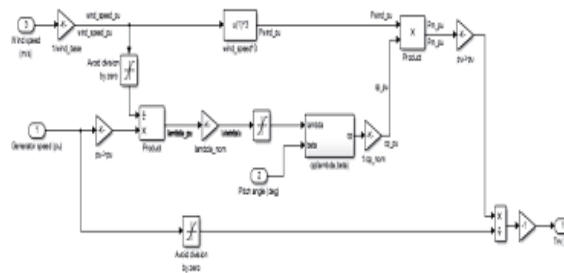

Fig. 2: Matlab model of wind turbine

3.2 Permanent Magnet Synchronous Generator

In WECS, wind turbine is coupled with a permanent magnet synchronous generator(PMSG).A permanent magnet synchronous machine block is taken in simulink.

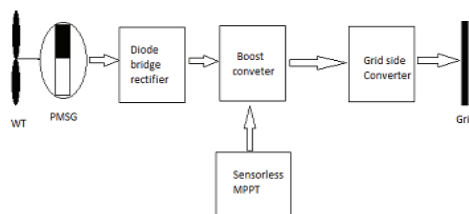

Fig.3 Block diagram of WECS

IV. SOLAR PV MODULE

The equivalent circuit of a PV cell is shown in fig.4. An ideal solar cell is modeled by a current source and a diode in parallel with it.

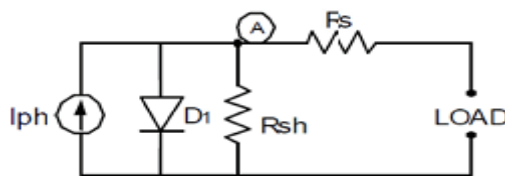

Fig.4 Equivalent circuit for PV module

By applying Kirchoffs current law, we get.

$$I_{ph} = I_d + I_{RP} + I \tag{9}$$

$$I = I_{ph} - (I_{RP} + I) \tag{10}$$

We get the following equation for the PV cell current

$$I = I_{ph} - (I_o \left[e \left(V + \frac{I R_s}{V_T} \right) - 1 \right] + V + I R_s / R_p) \tag{11}$$

Where I_{ph} is the isolation current, I is the cell current, I_o is the reverse saturation current, V is cell voltage, R_s is the series resistance, R_{sh} is the parallel resistance and V_t is the thermal voltage.

V. DC – DC CONVERTERS

DC-DC converters are used to convert a DC voltage at one level to another level, often providing regulating output.

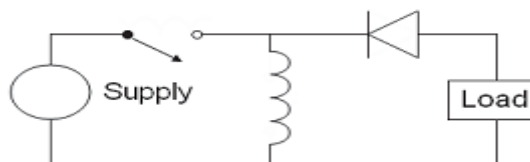

Fig. 5: Buck-Boost converter

A buck-boost converter provides an output voltage that may be lesser or greater than input voltage; the output voltage polarity is opposite to that of input voltage. This is also known as inverting regulator [6]. The circuit arrangement of buckboost converter is shown in Fig. 4.1. In steady state, the output-to-input conversion ratio is the product of the conversion ratios of the two converters in cascade

$$\frac{V_o}{V_d} = \frac{D}{1-D} \tag{12}$$

Where V_o = Output DC voltage, V_d = Input DC voltage, D = Duty ratio

In the process of extraction of maximum power from wind, MPPT technique uses the duty ratio information, and the triggering pulses are generated.

VI. MPPT TECHNIQUES

Maximum power point tracking (MPPT) techniques are used to maximize the output power by tracking continuously the maximum power point (MPP). Among various techniques, Hill Climbing Search (HCS) and Fuzzy Logic Controller (FLC) are used to extract maximum power for WECS. For solar PV module, Perturb & Observe (P&O) technique is used to extract maximum power from solar cell.

6.1 Hill Climbing Search

HCS is one of the simplest MPPT techniques where it requires power measurement only. This is based on perturbing the turbine shaft speed in small steps ($\Delta\omega$) and observing the resulting changes in turbine mechanical power increase or decrease. The various types of HCS techniques are: viz.fixed, variable and dual step size.

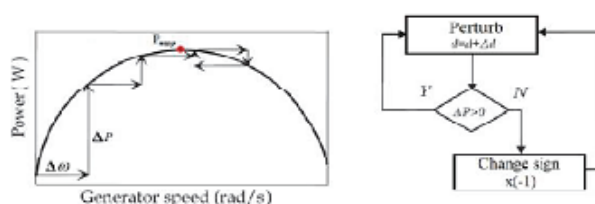

Fig. 6 : Principle of HCS

6.2 Fuzzy Logic Controller (FL)

A logical extension of HCS technique is Fuzzy logic technique which uses continuous varying step-size. The control decision is based only on If-else statement. Like HCS, Fuzzy logic do not require any system parameters or mathematical model. But it requires only rotational speed sensors.

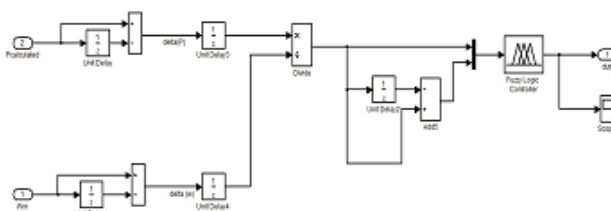

Fig. 7 : Block diagram of FLC

6.3 Perturb & Observe

In P&O method, the control adjusts the voltage by small amount from array and power will be measured. If power increases, adjustments will be done to maintain the power; this is P&O method. The only thing, this differs from HCS is in perturbation, in HCS it is on duty cycle and in P&O it is based on operating voltage of DC link between PV array and power converter.

VII. DC-AC INVERTER

A three phase inverter is used for DC-AC conversion. It is generally connected to grid, termed as Grid Side Converter (GSC).

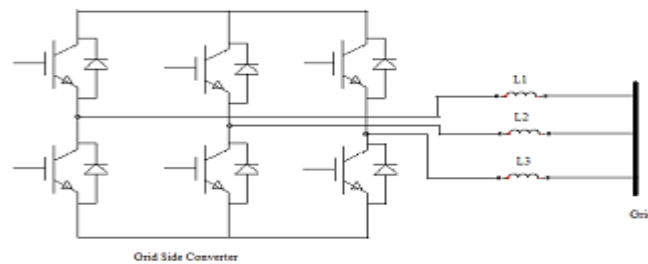

Fig. 8 : GSC (three phase inverter)

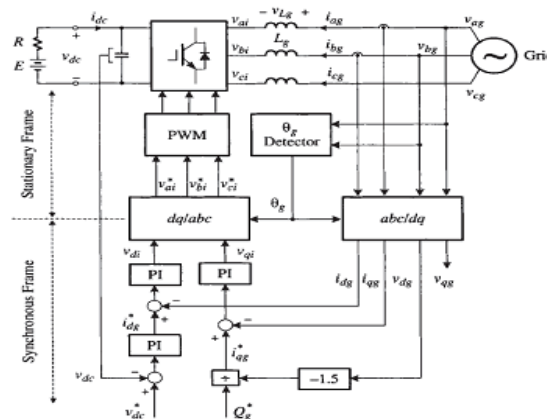

Fig. 9 : Block diagram for Control of GSC

A control technique called Voltage Oriented Control (VOC) is used for controlling the output voltages and current obtained from wind energy system. This technique includes double conversion of voltages, making use of transformation blocks (abc-dq) and current transformation to generate PWM output pulses to control inverter switches.

VIII. SIMULATION RESULTS

The simulation for hybrid model of wind and solar energy systems using Matlab/Simulink platform (Version R12a) is carried out.

The parameters for PMSG and Wind turbine are given below (Table 1 [1])

Wind Turbine Parameters	Value
Rated Power (MW)	2.3
Blade diameter (m)	71
Rated wind speed (m/s)	14
Number of blades	3
Turbine Inertia J_r (kg.m ²)	670
PMSG Parameters	Value
Rated Power (MW)	2
Rated Voltage (V)	690
Rated Stator Frequency (Hz)	11.25
Number of poles P	30
Stator Winding resistance R_s (mΩ)	0.73051
d-axis Synchronous Inductance L_d (mH)	1.21
q-axis Synchronous Inductance L_q (mH)	2.31
Flux Leakage (V.s)	4.696
Stator Leakage Inductance L_s (mH)	1.2
Rated Rotor Speed (rad/sec)	2.356
Generator Inertia J_G (kg.m ²)	8000
Peak line to neutral back emf constant	14.15
K_m (V/rpm)	

Table.1: Wind Turbine and PMSG Parameters [1]

The parameters of solar PV array are given in table 2.

Solar PV array Parameters	Value
Rated Power (W)	600
Open circuit voltage (V)	63.6
Short circuit current (A)	12.5
Optimum voltage (V)	42.4
Optimum current (A)	6.75

Table. 2 : Solar PV module Parameters

8.1 WEC system

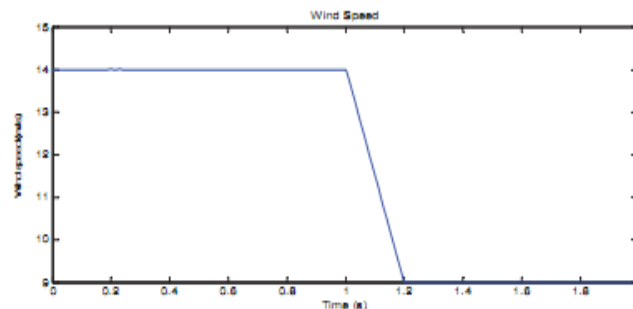

Fig. 10 : Wind speed

The plot of wind speed of Wind turbine is shown above. For specified duration of time the speed of turbine is 14m/s till 1sec and after that it is 9m/s. Characteristics are flat.

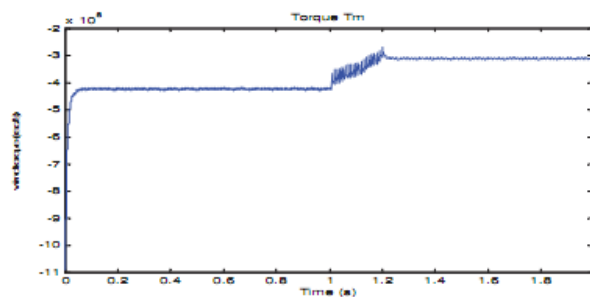

Fig. 11 : Wind torque

For wind speed of 14m/s the torque is 4.8×10^5 N-m. After 1sec speed is changed to 9m/s, for this speed the torque is 2×10^5 N-m. During change of torque from 4.8×10^5 to 2×10^5 we can observe oscillations in the plot, during the interval of 1s to 1.2s, and these oscillations are due to rapid change wind speed from 14m/s and 9m/s.

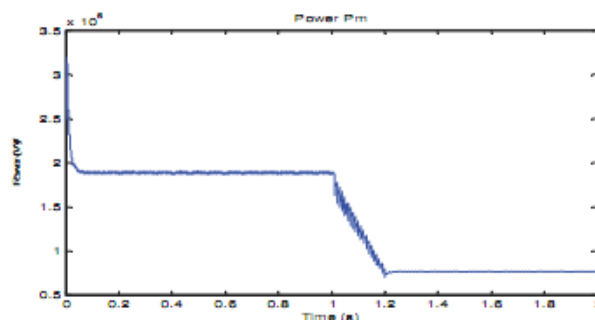

Fig. 12 : Output power

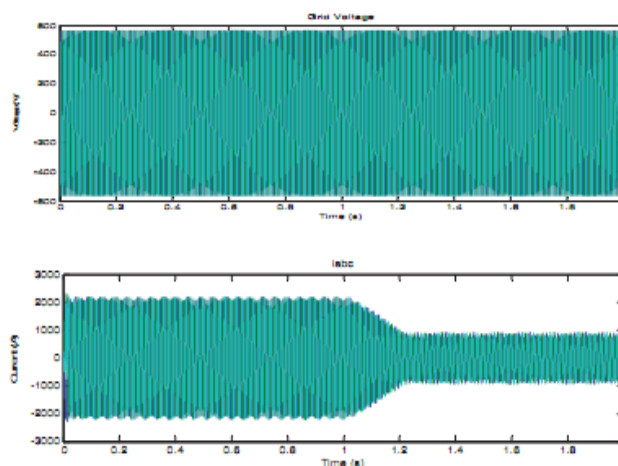

Fig. 13: Grid voltage and current

The three phase voltages and currents are shown for the simulation time of 2sec in Fig. 13. For the wind speed of 14m/s the currents are 2.2kA and for 9m/s it is 980A. The phase voltages V_{abc} are 600V.

8.2 Solar PV system

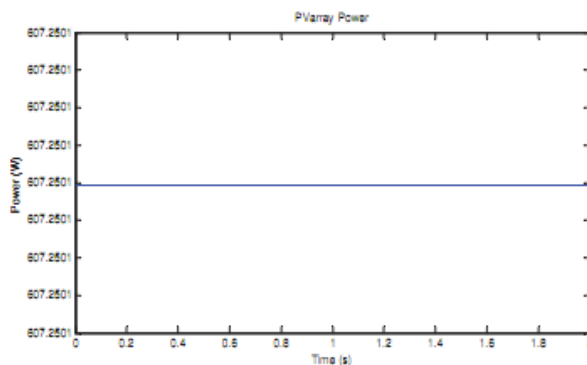

Fig. 14 : PV array power

The output of PV array is 600W.

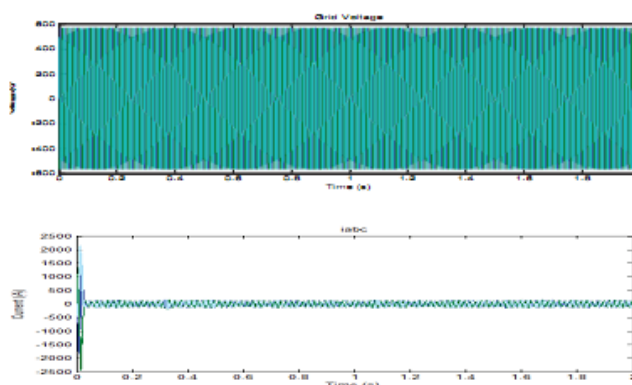

Fig. 15: Grid voltage and current

The three phase voltages and currents are shown for the simulation time of 2sec in Fig.15. The current is 150A and the phase voltages V_{abc} is 600V.

8.3 Hybrid system

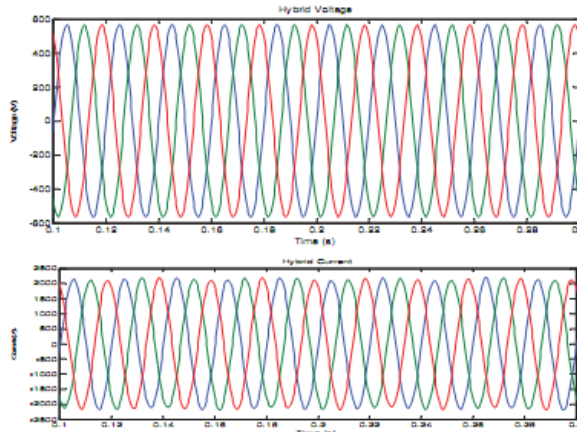

Fig. 16 : Voltage and current

The three phase voltages and currents of hybrid system are shown for the simulation time of 2sec. The current is 2.5kA and the phase voltages V_{abc} is 600V.

IX. CONCLUSION

This paper presents integration of grid connected PM wind energy system and Solar PV system using different MPPT techniques. Two different MPPT techniques are employed for wind energy system and another for solar. Hill climbing search (HCS) and Fuzzy Logic (FL) are employed for WECS. For solar energy system Perturb & Observe (P&O) is introduced. The results are verified using Matlab/ Simulink platform.

REFERENCES

- [1]. A.M.El-Sebaai, M.S.Hamad and A.A.Helal “A Sensorless MPPT Technique for a Grid Connected PMSG Wind Turbine System”, Arab Academy for science, Technology and Maritime Transport, Egypt
- [2]. Sonam Mishra, M. Gupta, Araati Garag, Rahul. G, Vimal Kumar Mishra, “ Modelling and Simulation of Solar Photo-Voltaic and PMSG Based Wind Hybrid System”, 2014 IEEE students’ Conference on Electrical, Electronics and Computer Science
- [3]. R.Esmili, L.Xu, D.K.Nichols, “A New Control Method Of PMSG For Maximum Point Tracking In Wind Turbine Application,” IEEE Ower Engineering Society General Meeting, Vol.3, June 2005, Pp.2090-2095
- [4]. M.A. Abdullah, A.H.M.Yatim,C.W.Tan, “A Study Of Maximum Power Point Tracking Algorithm For Wind Energy System”, IEEE First Conference On Clean Energy And Technology CET, 2011. Pp.321-326
- [5]. Y.Xia, K.H.Ahmed, B.W.Williams, “A New Maximum Power Point Tracking Technique For Permanent Magnet Synchronous Generator Based Wind Energy Conversion System,” iee transactions onpower electronics, vol.26, no.12 december 2011, pp.3609-3620.