

REMOTE CONTROL BASED POWER LED STREET LIGHTING

**Kuldeep Singh¹, Devesh Gupta², Navnit Kumar Sinha³,
Md. Rahil Anwar⁴, Amrish Dubey⁵**

^{1, 2, 3, 4} Students, Electrical Engineering Department Greater Noida Institutes of Technology, Gr.Noida, (India)

⁵ Assistant Professor, Electrical Engineering Department Greater Noida Institutes of Technology, Gr. Noida, (India)

ABSTRACT

We propose an innovative wireless street lighting system by using power LED with optimized management and efficiency. Wireless communication uses RF transmission system which allows more efficient street lamp system management, thanks to an advanced interface and control architecture. It uses many sensors to control and guarantee the optimal system parameters. One benefit LEDs offer in general lighting applications is that they are easier to control remotely.

Keywords: Power LED, RF Receiver, RF Transmitter & Circuit Design

I. INTRODUCTION

Lighting systems, particularly within the public sector, are still designed per the previous standards of reliability and that they don't usually profit of latest technological developments.

Recently, however, the increasing pressure associated with the raw material prices and also the increasing social sensitivity to CO₂ emissions are leading to develop new techniques and technologies which permit significant cost savings and larger respect for the environment. In the literature we will notice three solutions to those issues.

The first one, and maybe the most intuitive, is the use of recent technologies for the sources of light. The LED technology is thought as best solution but it offers several edges. Researchers have already thought of this risk, coming up with advanced street lighting system based mostly on LEDs.

The second resolution, and perhaps the most revolutionary, is to use of remote management system based mostly on intelligent lampposts that send info to a central management system, simplifying the management and maintenance. We have developed street lamp system using the RF transmission. Our work aims at unification of the three prospects, making an intelligent lamppost managed by a remote controlled system that uses LED-based light supply and is powered by DC supply.

II. GENERAL CONCEPT OF THE SYSTEM

The System Consist of RF wireless transmission System for controlling the supply of Street light (Power LEDs). The system consist various devices as follows-

2.1 Power LEDs

High power LED is a light emitting diode with high rated current. Low power LED is generally 0.1W, operating current is 20mA, but high power LED can reach 1W, 2W, or even tens of watts, operating current can be range from tens of mA to several hundred mA. Due to the constraints of flux conversion efficiency and cost, it decides high-power mainly used in some special lighting areas in short-term, and long-term goal is the general lighting.

2.1.1 High power LED advantages

High-power LED as the light source with features of low power consumption, less heating, long life, fast response, good direction and so on. Housing is available for PC pipe, able to bear high temperature of 135 degrees, low temperature of -45 degrees.

2.2 Wireless Transmitter and Receiver using ASK RF Module

A wireless radio frequency (RF) transmitter and receiver can be easily made using **HT12D** Decoder, **HT12E** Encoder and ASK RF Module. Wireless transmission can be done by using 433Mhz or 315MHz ASK RF Transmitter and Receiver modules. In these modules digital data is represented by different amplitudes of the carrier wave, hence this modulation is known as Amplitude Shift Keying (ASK). Radio Frequency (RF) transmission is more strong and reliable than Infrared (IR) transmission due to following reasons :

- Radio Frequency signals can travel longer distances than Infrared.
- Only line of sight communication is possible through Infrared while radio frequency signals can be transmitted even when there is obstacles.
- Infrared signals will get interfeared by other IR sources but signals on one frequency band in RF will not interfeared by other frequency RF signals.

III. TRANSMITTER CIRCUIT DIAGRAM

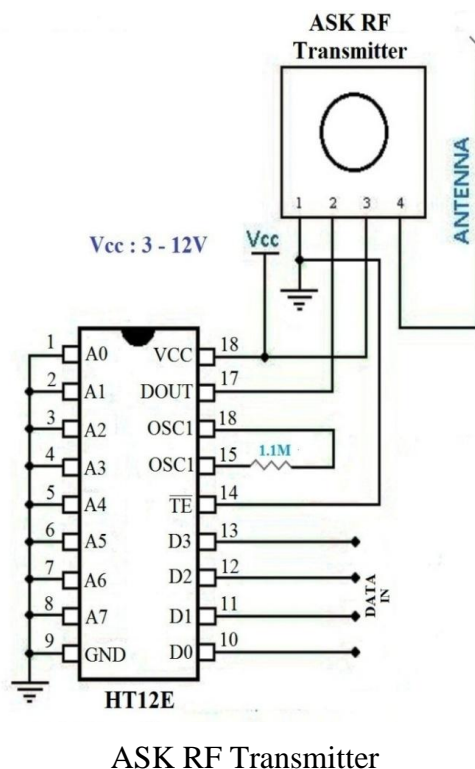

HT12E Encoder IC will convert the 4 bit parallel data given to pins D0 – D3 to serial data and will be available at DOUT. This output serial data is given to ASK RF Transmitter. Address inputs A0 – A7 can be used to provide data security and can be connected to GND (Logic ZERO) or left open (Logic ONE). Status of these Address pins should match with status of address pins in the receiver for the transmission of the data. Data will be transmitted only when the Transmit Enable pin (TE) is LOW. 1.1MΩ resistor will provide the necessary external resistance for the operation of the internal oscillator of **HT12E**.

IV. RECEIVER CIRCUIT DIAGRAM

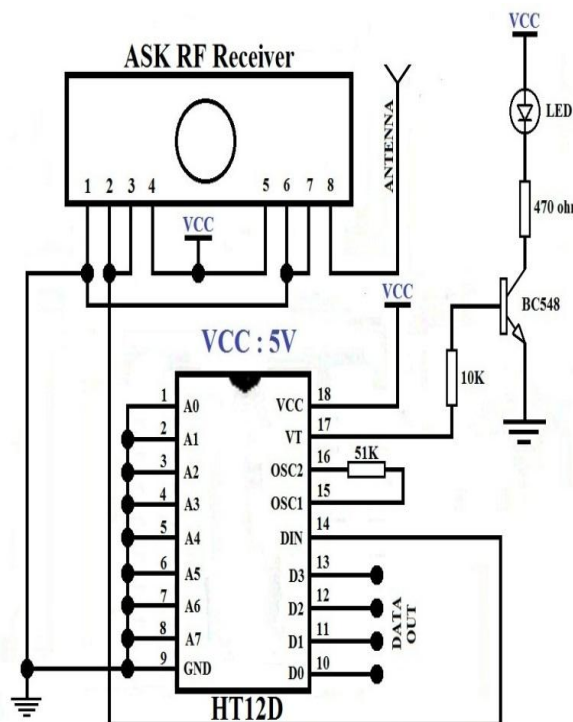

ASK RF Receiver

ASK RF Receiver receives the data transmitted using **ASK RF** Transmitter. **HT12D** decoder will convert the received serial data to 4 bit parallel data D0 – D3. The status of these address pins A0-A7 should match with status of address pin in the **HT12E** at the transmitter for the transmission of data. The LED connected to the above circuit glows when valid data transmission occurs from transmitter to receiver. 51KΩ resistor will provide the necessary resistance required for the internal oscillator of the **HT12D**.

4.1 HT12D

HT12D is a **decoder integrated circuit** that belongs to 2¹² series of decoders. This series of decoders are mainly used for remote control system applications, like burglar alarm, car door controller, security system etc. It is mainly provided to interface RF and infrared circuits. They are paired with 2¹² series of encoders. The chosen pair of encoder/decoder should have same number of addresses and data format. In simple terms, HT12D converts the serial input into parallel outputs. It decodes the serial addresses and data received by, say, an RF receiver, into parallel data and sends them to output data pins. The serial input data is compared with the local addresses three times continuously. The input data code is decoded when no error or unmatched codes are

found. A valid transmission is indicated by a high signal at VT pin. HT12D is capable of decoding 12 bits, of which 8 are address bits and 4 are data bits. The data on 4 bit latch type output pins remain unchanged until new is received.

4.2 HT12E

HT12E is an encoder integrated circuit of 2^{12} series of encoders. They are paired with 2^{12} series of decoders for use in remote control system applications. It is mainly used in interfacing RF and infrared circuits. The chosen pair of encoder/decoder should have same number of addresses and data format. Simply put, HT12E converts the parallel inputs into serial output. It encodes the 12 bit parallel data into serial for transmission through an RF transmitter. These 12 bits are divided into 8 address bits and 4 data bits. HT12E has a transmission enable pin which is active low. When a trigger signal is received on TE pin, the programmed addresses/data are transmitted together with the header bits via an RF or an infrared transmission medium. HT12E begins a 4-word transmission cycle upon receipt of a transmission enable. This cycle is repeated as long as TE is kept low. As soon as TE returns to high, the encoder output completes its final cycle and then stops.

V. CONCLUSIONS

In this paper a proposal of an intelligent street lighting system is described that integrates new technologies, offering ease of maintenance and energy savings. This is obtained by using the highly economical LED technology. The proposed system is especially appropriate for street lighting in remote urban and rural areas. The system is versatile, extendable and totally adjustable to user needs. It will reduce the use of wires that enables user to control it from some distance .

REFERENCE

- [1]. Digital Integrated Circuits (2nd Edition) 2nd Edition by Jan M. Rabaey, Anantha Chandrakasan, Borivoje Nikolic.
- [2]. www.engineersgarage.com/electronic-components
- [3]. K.Y.Rajput, G.Khatav, M.Pujari, P.Yadav, Intelligent Street Lighting System Using Gsm, International Journal of Engineering Science Invention, Vol2, Issue3, March2013.
- [4]. <https://en.wikipedia.org/wiki/LEDstreetlight>
- [5]. K.S.Sudhakar, A.A.Anil, K.C. Ashok S.S. Bhaskar, Automatic Street Light Control System, *International Journal of Emerging Technology & Advanced Engineering*, Vol. 3, May2013, PP.188-189.